

POLY 2020.1 HP RTE.1 - RT4.1

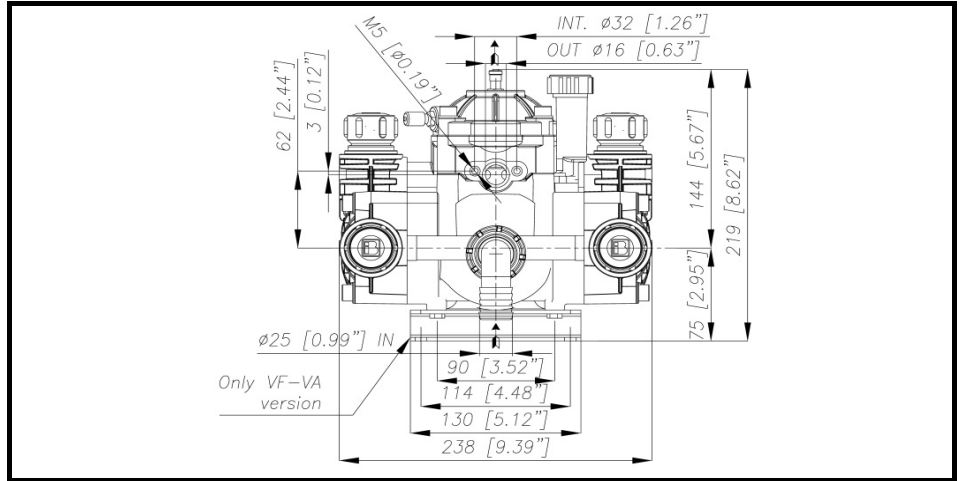

DIMENSIONI D'INGOMBRO - OVERALL DIMENSIONS



ALBERO POMPA - PUMP SHAFT

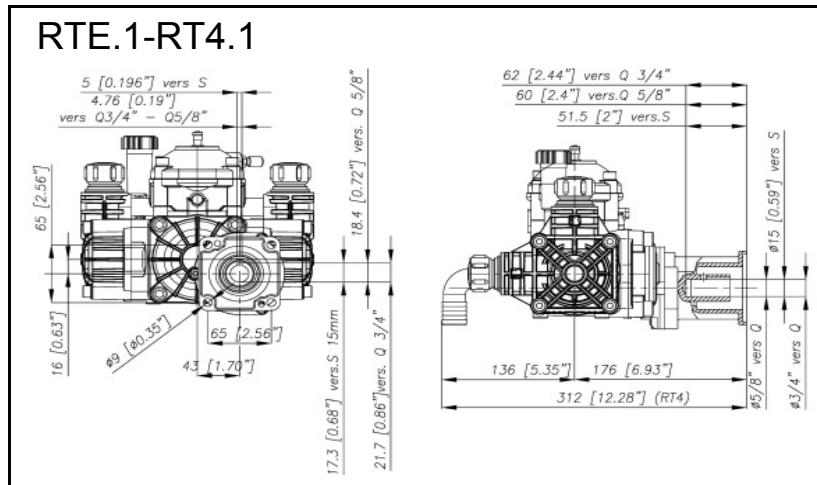

COPPIA DI SERRAGGIO - TORQUE CHART

CODICE - CODE	Q.TY	POS	N-m	Lbr.ft
94.0419.32.2	4	6	10	7.4
86.2951.00.2	2	10	10	7.4
86.1606.00.2	1	12	5	3.7
86.2900.00.2	8	22	12	8.5
03.0021.97.3	2	25	5(*)	3.7
86.2945.00.2	2	38	10	7.4
86.3300.00.2	4	44	40	29.5
81.4545.00.2	3-5	45	10	7.4
86.2301.00.2	2	47	10	7.4
83.8012.00.2	1	52	10	7.4
86.2260.00.2	2	55	10	7.4
86.2108.00.2	2	58	10	7.4
86.1948.00.2	1	68	6	4.4
Tolleranza di serraggio - Tolerance on torque value:			0/-10%(*)	
Tolleranza generale - General tolerance :			0/-20%	

INFORMAZIONI UTILI USEFUL INFORMATION

LUBRIFICANTE - LUBRICANT:

POMPA - PUMP:
OLIO MOTORE O SEMIIDRAULICO SAE 30
MOTOR OIL OR SEMI-HYDRAULIC OIL SAE 30

PRESSIONE ACCUMULATORE ACCUMULATOR PRESSURE

PRESSIONE DI LAVORO - OPERATING PRESSURE	2 ÷ 5	5÷10	10 ÷ 20	20 ÷ 50
ACCUMULATORE ACCUMULATOR	2	2 ÷ 5	5 ÷ 7	6 ÷ 8

KIT MEMBRANE - DIAPHRAGMS KIT

KIT	94.9871.97.3	BUNA - N			94.9943.97.3	VITON					94.9918.97.3	PRE-SET DESMOPAN					94.9918.97.3DS	PRE-SET DURAMAX				
POSIZIONE ESPLOSO POSITION NUMBER		1	13	16		1	13	16	3	5		1	13	16	3	5		1	13	16	5	3
QUANTITA' NEL KIT QUANTITIES INCLUDED		2	1	4		2	1	4	4	4		2	1	4	4	4		2	1	4	4	4

KIT POMPA/KIT VALVOLE - PUMP KIT/VALVES KIT

KIT	94.9942.97.3	KIT POMPA PUMP KIT							94.9944.97.3	KIT VALVOLE VALVE KIT			
POSIZIONE ESPLOSO POSITION NUMBER		16	67	69	73	3	27	43		2	3	4	5
QUANTITA' NEL KIT QUANTITIES INCLUDED		4	1	1	1	4	1	1		4	4	2	4

POLY 2020.1 HP RTE.1 - RT4.1

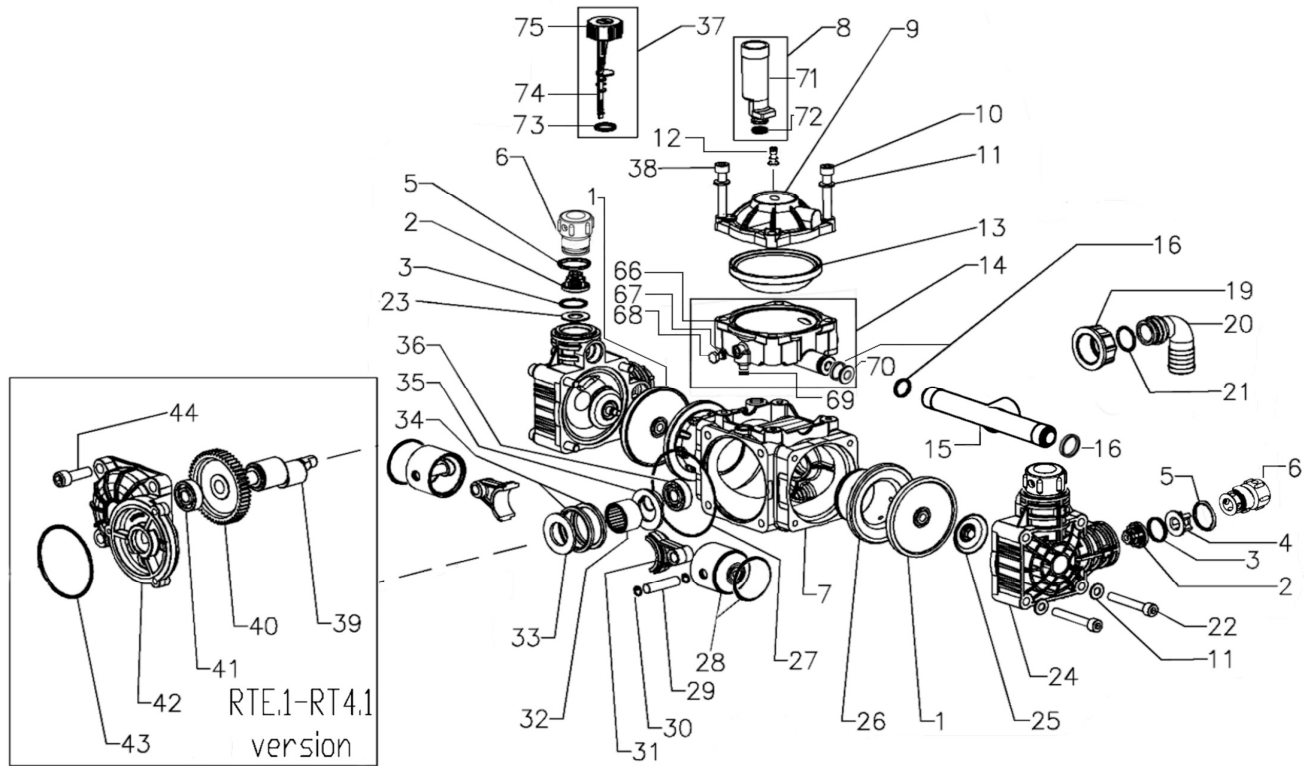

VERSIONS		OPTIONAL	
RT4.1	RTE.1	SAFETY VALVE	

POS.	CODICE PART NO. REF.	DENOMINAZIONE - DESCRIPTION - DESCRIPTION	Q.TY	CONF. PACK.	POS.	CODICE PART NO. REF.	DENOMINAZIONE - DESCRIPTION - DESCRIPTION	Q.TY	CONF. PACK.
1	94.0040.31.2	BUNA-N PISTON DIAPHRAGM(OPT.)	2		41	81.2522.00.2	BALL BEARING	1	
1	94.0042.00.2	PRE-SET DESMOPAN PISTON DIAPH.(OPT.)	2		42	94.0383.09.2	CRANKCASE	1	
1	94.0042.00.2DS	PRE-SET DURAMAX PISTON DIAPHRAGM (STD)	2		43	80.3210.64.2	O-RING	1	●
1	94.0040.33.2	VITON PISTON DIAPHRAGM(OPT.)	2		44	86.3300.00.2	SCREW [40Nm - 29.5lb-ft]	4	●
2	03.9821.97.3	VALVE ASSY	4		66	94.0316.32.2	LOWER DAMPER (X PBP)	1	
3	80.3200.50.2	O-RING	4	▲	67	80.3049.00.2	O-RING	1	●
4	94.0389.32.2	SPACER INLET VALVE	2		68	86.1948.00.2	SCREW [6Nm - 4,4lb-ft]	1	●
5	80.3205.55.2	O-RING	4	▲	69	80.3170.00.2	O-RING	1	●
6	94.0419.32.2	CAP [10Nm - 7,4lb-ft]	4		70	94.0316.32.2	BUSHING	2	
7	94.0301.09.2	CRANKCASE	1		71	94.0307.32.2	OIL TANK	1	
8	94.9866.97.3	KIT OIL FILLER	1		72	80.3213.50.2	O-RING	1	●
9	94.0003.09.2	DAMPER COVER	1		73	80.3181.00.2	O-RING	1	●
10	86.2951.00.2	SCREW [10Nm - 7,4lb-ft]	2	▲	74	94.0353.32.2	OIL LEVEL DIP	1	●
11	84.3685.00.2	WASHER	12	●	75	85.2698.00.2	CAP	1	
12	86.1606.00.2	AIR VALVE [5Nm - 3,7lb-ft]	1		79	24.3202.97.3	SAFETY VALVE 15BAR (OPTIONAL)	1	
13	94.0041.31.2	DAMPER DIAPHRAGM	1				RT4.1		
14	94.9867.97.3	LOWER DAMPER BODY(X PBP)	1		45	81.4545.00.2	NUT [10Nm - 7,4lb-ft]	3	●
15	94.0421.32.2	INLET MANIFOLD	1		46	84.3585.00.2	WASHER	3	●
16	80.3181.10.2	O-RING	4	▲	47	86.2301.00.2	SCREW [10Nm - 7,4lb-ft] ●	2	●
19	82.0045.50.2	WING NUT G-1	1	▲	48	94.0210.09.2	MOTOR FLANGE	1	
20	84.0526.00.2	SUCTION CONNECTOR D.25 A 90°	1		49	94.0403.42.2A	PINION	1	
21	80.3195.50.2	O-RING	1	▲	49	94.0401.42.2A	PINION	1	
22	86.2900.00.2	SCREW [12Nm - 8,85lb-ft] ●	2	●	49	94.0402.42.2A	PINION	1	
23	94.0397.68.2	WASHER	8	▲	50	80.6436.00.2	TAB (D.3/4"D.5/8")	1	
24	94.0390.32.2	PUMP HEAD	2		50	80.6445.00.2	TAB (D.15)	1	▲
25	03.0021.97.3	KIT DIAP WASH./SCREW.INOX [5Nm - 3,7lb-ft](*)	2		51	80.2117.00.2	OIL SEAL	1	
26	94.0007.01.2	PISTON SLEEVE	2		52	83.8012.00.2	STUD [10Nm - 7,4lb-ft]	1	▲
27	80.3080.90.2	O-RING 1,78x82,27	1	●			RTE.1		
28	94.0117.09.3	PISTON WITH PISTON RING	2		52	83.8012.00.2	STUD [10Nm - 7,4lb-ft]	1	▲
29	85.2006.00.2	PISTON PIN	2		53	81.2631.00.2	BALL BEARING	1	
30	80.0003.00.2	SNAP RING	4	●	54	84.3585.00.2	WASHER	3	●
31	94.0008.09.2	CONROD	2		55	86.2260.00.2	SCREW [10Nm - 7,4lb-ft]	2	●
32	81.2688.00.2	BEARING	1		56	81.4545.00.2	NUT	5	●
33	94.0027.32.2	SPACER	1	▲	57	83.2081.40.2	EL. MOTOR	1	
34	94.0047.76.2	CONROD RING	2		57	83.2081.80.2	EL. MOTOR	1	
35	94.0392.32.2	SHAFT SPACER	1		58	86.2108.00.2	SCREW [10Nm - 7,4lb-ft]	1	●
36	81.2522.00.2	BALL BEARING	1		59	31.1324.61.2	LEFT HALF HANDLE	1	
37	94.9855.97.3	KIT OIL INDICATOR	1		60	82.8410.00.2	KNOB	1	
38	86.2945.00.2	SCREW [10Nm - 7,4lb-ft]	2	●	61	31.1325.61.2	RIGHT HALF HANDLE	1	
39	94.0384.26.2	SHAFT	1		62	94.0404.61.2	BRACKET	1	
40	94.0400.42.2	GEAR	1		63	80.2072.00.2	OIL SEAL	1	

Torque values are indicated between brackets []. General Tolerance on torque value: 0/-20% . Tolerance on torque value: 0/-10% (*)
 The components marked with the symbols are supplied in packs: ▲ = 12pcs. ● = 25pcs.