

POLY 2020.1 HP VF-VA-RTE.1 - RT4.1

DIMENSIONI D'INGOMBRO - OVERALL DIMENSIONS

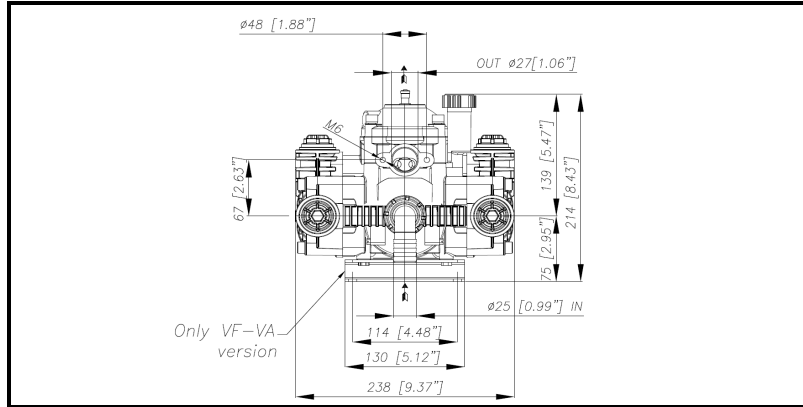

ALBERO POMPA - PUMP SHAFT

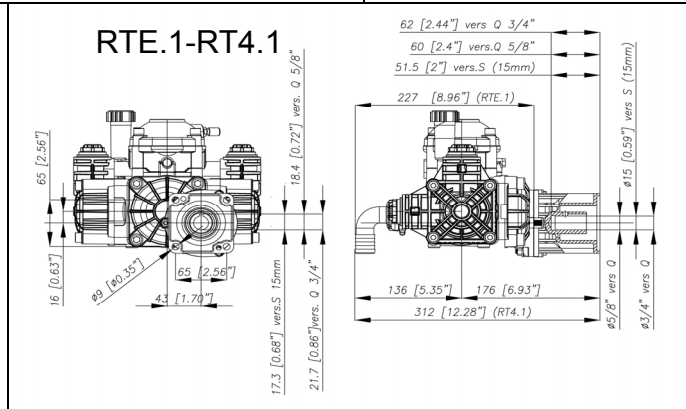
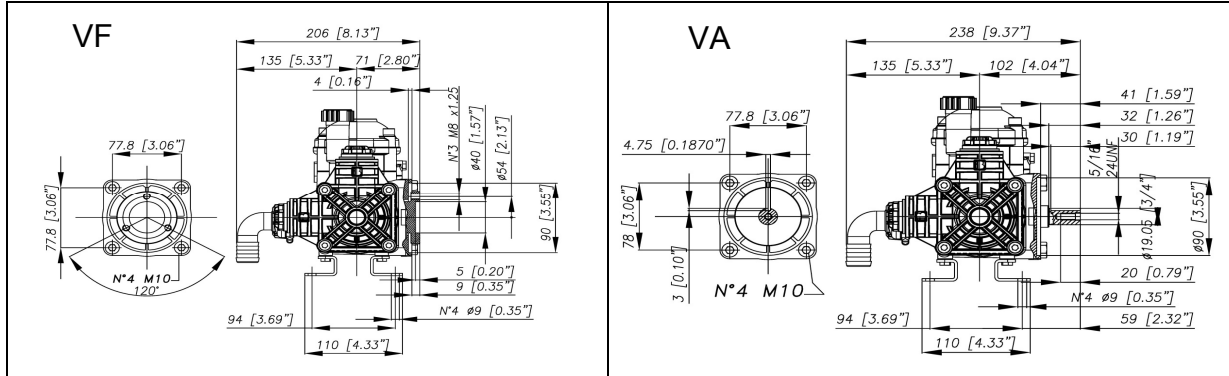

COPPIA DI SERRAGGIO - TORQUE CHART					
CODICE - CODE	Q.TY	POS	N-m	Lbr.ft	
86.2900.00.2	8	22	10	7.4	
03.0021.97.3	2	25	5	3.7	
86.1605.00.2	1	12	5	3.7	
86.2945.00.2	2	38	10	7.4	
86.2951.00.2	2	10	10	7.4	
86.3300.00.2	4	44	40	29.5	
86.2301.00.2	2	47	10	7.4	
83.8012.00.2	1	52	10	7.4	
86.2260.00.2	2	55	10	7.4	
86.2108.00.2	2	58	10	7.4	
81.4545.00.2	3-5	45	10	7.4	
11.0152.32.2	4	6	10	7.4	
86.2059.00.2	4	65	10	7.4	
86.3185.00.2	4	70	40	29.5	
86.3185.00.2	4	77	40	29.5	

Tolleranza di serraggio - Tolerance on torque value: 0/-10%

INFORMAZIONI UTILI USEFUL INFORMATION				
LUBRIFICANTE - LUBRICANT:				
POMPA - PUMP: OLIO MOTORE O SEMIDRAULICO SAE 30 MOTOR OIL OR SEMI-HYDRAULIC OIL SAE 30				
PRESSIONE ACCUMULATORE ACCUMULATOR PRESSURE				
PRESSIONE DI LAVORO - OPERATING PRESSURE	2 + 5	5 + 10	10 + 20	20 + 50
ACCUMULATORE ACCUMULATOR	2	2 + 5	5 + 7	6 + 8

KIT MEMBRANE - DIAPHRAGMS KIT

KIT	BUNA - N				VITON					PRE-SET DESMOPAN					PRE-SET DURAMAX				
	1	13	16	14	1	13	16	3	5	1	13	16	3	5	1	13	16	3	5
POSIZIONE ESPLOSO POSITION NUMBER	94.9871.97.3				94.9943.97.3					94.9918.97.3					94.9918.97.3DS				
QUANTITA' NEL KIT QUANTITIES INCLUDED	2	1	4	4	2	1	4	4	4	2	1	4	4	4	2	1	4	4	4

KIT POMPA/KIT VALVOLE - PUMP KIT/VALVES KIT

KIT	KIT POMPA PUMP KIT						KIT VALVOLE VALVE KIT			
	10	15	6	4	22	30	3	4	5	
POSIZIONE ESPLOSO POSITION NUMBER	94.9942.97.3						94.9944.97.3			
QUANTITA' NEL KIT QUANTITIES INCLUDED	2	4	2	2	1	1	4	4	2	4

POLY 2020.1 HP VF - VA - RTE.1 - RT4.1

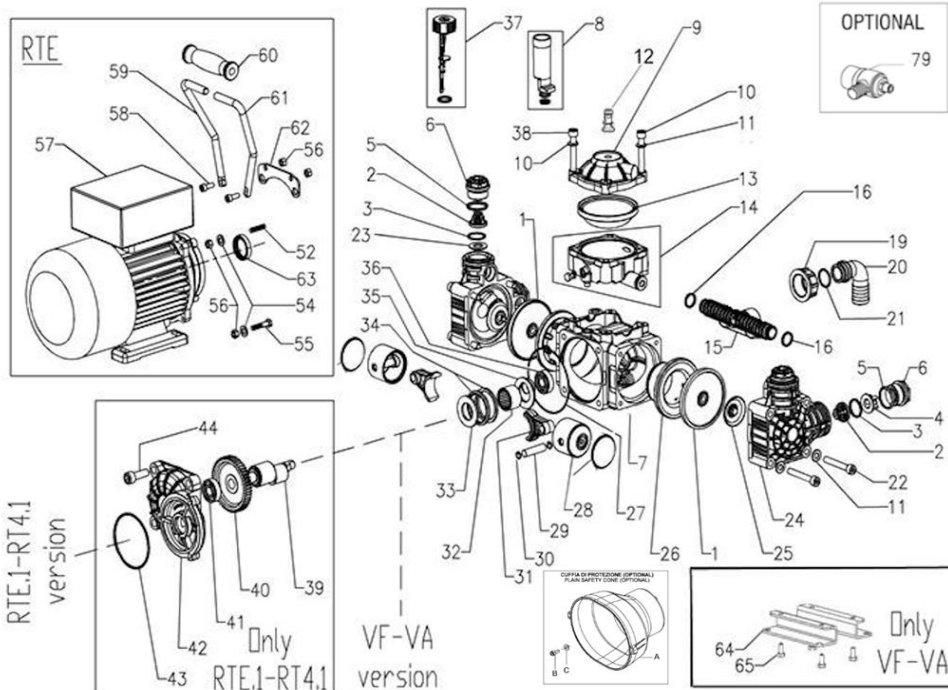

VERSIONI

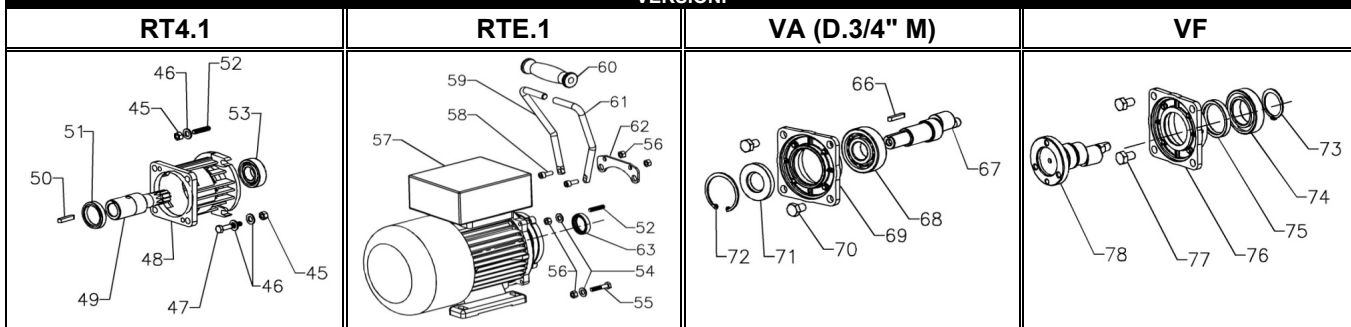

POS.	CODICE PART NO. REF.	DENOMINAZIONE - DESCRIPTION - DESCRIPTION	Q.TY	POS.	CODICE PART NO. REF.	DENOMINAZIONE - DESCRIPTION - DESCRIPTION	Q.TY
1	94.0042.00.2DS	PRE-SET DURAMAX PISTON DIAPHRAGM (std.)	2	41	81.2522.00.2	BALL BEARING	1
1	94.0042.00.2	PRE-SET DESMOPAN PISTON DIAPHRAGM (opt.)	2	42	94.0383.09.2	CRANKCASE	1
1	94.0040.31.2	PISTON DIAPHRAGM (opt.)	2	43	80.3210.64.2	O-RING 2.62X75.87	1
1	94.0040.33.2	VITON PISTON DIAPHRAGM (opt.)	2	44	86.3300.00.2	SCREW M10X30 UNI5931	4
2	03.9821.97.3	VALVE ASSY	4	45	81.4545.00.2	NUT M6 UNI5587	3
3	80.3200.50.2	O-RING D.2,62X22,22	4	46	84.3585.00.2	WASHER D.6 UNI6592	3
4	94.0389.32.2	SPACER INLET VALVE	2	47	86.2301.00.2	SCREW M6X35 UNI 5737	2
5	80.3205.55.2	O-RING D.2,62X26,65	4	48	94.0210.09.2	MOTOR FLANGE	1
6	94.0419.32.2	CAP	4	49	94.0403.42.2	PINION Z=9 (D.3/4")	1
7	94.0301.09.2	CRANKCASE	1	49	94.0401.42.2	PINION Z=9 (D.15)	1
8	94.9866.97.3	KIT OIL FILLER	1	49	94.0402.42.2	PINION Z=9 (D.5/8")	1
9	94.0003.09.2	DAMPER COVER	1	50	80.6436.00.2	TAB 4,75X5X30 (D.3/4"D.5/8")	1
10	86.2951.00.2	SCREW M8X65 UNI5931	2	50	80.6445.00.2	TAB 5X5X30 (D.15)	1
11	84.3685.00.2	WASHER D.8,2X15X1,5	12	51	80.2117.00.2	OIL SEAL 30X40X7	1
12	86.1606.00.2	AIR VALVE	1	52	83.8012.00.2	STUD M6X18 UNI5911	1
13	94.0041.31.2	DAMPER DIAPHRAGM	1	53	81.2631.00.2	BALL BEARING	1
14	94.9924.97.3	LOWER DAMPER BODY (FOR KARIN)	1	54	84.3585.00.2	WASHER D.6 UNI6592	3
14	94.0316.32.2	LOWER DAMPER BODY (FOR PBP)	1	55	86.2260.00.2	SCREW M6X30 UNI 5737	2
15	94.0421.32.2	INLET MANIFOLD	1	56	81.4545.00.2	NUT M6 UNI5587	5
16	80.3181.10.2	O-RING D.2,62X15,54	4	57	83.2081.70.2	EL. MOTOR 230V (Z=9)	1
19	82.0045.50.2	WING NUT G.1	1	57	83.2081.80.2	EL. MOTOR 400V (Z=9)	1
20	84.0526.00.2	SUCTION CONNECTOR D.25 A 90°	1	58	86.2108.00.2	SCREW M6X16 UNI5931	1
21	80.3195.50.2	O-RING D.2,62X20,29	1	59	31.1324.61.2	LEFT HALF HANDLE	1
22	86.2900.00.2	SCREW TCEI M8X55	2	60	82.8410.00.2	KNOB	1
23	94.0397.68.2	WASHER	8	61	31.1325.61.2	RIGHT HALF HANDLE	1
24	94.0390.32.2	PUMP HEAD	2	62	94.0404.61.2	BRACKET	1
25	03.0021.97.3	KIT DIAPHRAGM WASHER/SCREW AISI 316	2	63	80.2072.00.2	OIL SEAL 20X35X7	1
26	94.0007.01.2	PISTON SLEEVE	2	64	94.0420.61.2	MOUNTING RAIL	2
27	80.3080.90.2	O-RING 1,78X82,27	1	65	86.2086.00.2	SCREW TCEI M6X14 UNI5931	4
28	94.0117.09.3	PISTON WITH PISTON RING	2	66	80.6436.00.2	TAB 4,75X5X30	1
29	85.2006.00.2	PISTON PIN	2	67	94.0323.26.2	SHAFT VA	1
30	80.0003.00.2	SNAP RING DIA.10	4	68	81.2725.00.2	BEARING 25X62X17	1
31	94.0008.09.2	CONROD	2	69	94.0336.09.2	FLANGE VA	1
32	81.2688.00.2	BEARING	1	70	86.3185.00.2	SCREW M10X16 UNI5739	4
33	94.0027.32.2	SPACER	1	71	80.2099.90.2	OIL SEAL 25X52X7	1
34	94.0047.76.2	CONROD RING	2	72	80.1369.00.2	RING D.52	1
35	94.0392.32.2	SHAFT SPACER	1	73	80.1264.00.2	RING D.35	1
36	81.2522.00.2	BALL BEARING	1	74	81.2837.00.2	BEARING 35X62X14	1
37	94.9855.97.3	KIT OIL INDICATOR	1	75	80.2178.10.2	OIL SEAL 40X52X7	1
38	86.2945.00.2	SCREW M 8X60 UNI 5931	2	76	94.0326.09.2	FLANGE VF	1
39	94.0384.26.2	SHAFT POLY 2020 RT4.1	1	77	86.3185.00.2	SCREW M10X16 UNI5739	4
40	94.0400.42.2	GEAR Z=48	1	78	94.0335.26.2	SHAFT VF	1