

# ARTICOLI VARI ASSORTED ITEMS ARTICULOS VARIOS

Una serie di prodotti messi a punto negli anni per rendere sempre più completa l'offerta ARAG e quindi semplificare il lavoro dei nostri clienti, che all'interno di questa sezione possono trovare i componenti per completare al meglio le loro macchine.

A series of products designed over the years to complete the ARAG line and thus simplify our customers work. This section offers our customers a wide choice of parts to complete their machines.

Una serie de productos perfeccionados con los años para completar aún más la oferta ARAG y simplificar así el trabajo de nuestros clientes, que en esta sección podrán encontrar los componentes necesarios para completar sus máquinas.

## Legenda dei simboli - Symbols - Leyenda simbolos



Raccordo con attacco a forchetta  
Fitting with fork coupling  
Racor con conexion de horquilla



Pressione di esercizio  
Operating pressure  
Presión de trabajo



Portata  
Flow rate  
Caudal



Nuovi prodotti  
New items  
Nuevos productos



Prodotto codificato secondo norma ISO19732  
Product codified in compliance with the Standard ISO19732  
Codificación del producto según la norma ISO19732



Valore tipico di assorbimento  
Typical absorption  
Valor tipico de absorcion



Dimensioni di ingombro  
Overall dimensions  
Dimensiones máximas



Nuovi prodotti  
New items  
Nuevos productos

**POMPE CENTRIFUGHE MULTISTADIO  
MULTISTAGE CENTRIFUGAL PUMPS  
BOMBAS CENTRÍFUGAS MULTIETAPAS**

**MSP**  
SERIES

Le pompe ARAG serie MSP sono le prime pompe multistadio progettate appositamente per macchine agricole da irrorazione e diserbo.

L'utilizzo di più giranti ha permesso di realizzare una serie di pompe costruite prevalentemente con tecnopolimeri ad elevata resistenza così da garantire un'eccellente compatibilità con i prodotti chimici utilizzati in agricoltura ad un prezzo molto vantaggioso rispetto alle pompe in acciaio inox.

L'attenta progettazione ha consentito di ottenere elevate pressioni di esercizio anche ad un ridotto numero di giri, che si traduce in una maggiore vita di tutti i componenti.

The MSP series ARAG pumps are the first multi-stage pumps designed specifically for sprayers and crop sprayers.

The use of multiple impellers has made it possible to manufacture a series of pumps made predominantly with highly resistant engineering plastic to ensure excellent compatibility with the chemicals used in agriculture, at a very competitive price compared to stainless steel pumps.

Precise design has made it possible to achieve high operating pressures even at a reduced number of revolutions, which translates into a longer life for all components.

Las bombas ARAG serie MSP son las primeras bombas multietapa diseñadas específicamente para máquinas agrícolas de pulverización y tratamiento con barras.

El uso de varios rotores ha permitido realizar una serie de bombas construidas principalmente con tecnopolímeros de elevada resistencia para garantizar una excelente compatibilidad con los productos químicos utilizados en agricultura a un precio muy ventajoso en comparación con las bombas de acero inoxidable.

Su atento diseño ha permitido obtener elevadas presiones de ejercicio incluso con reducido número de revoluciones, lo que se traduce en una mayor duración de todos sus componentes.

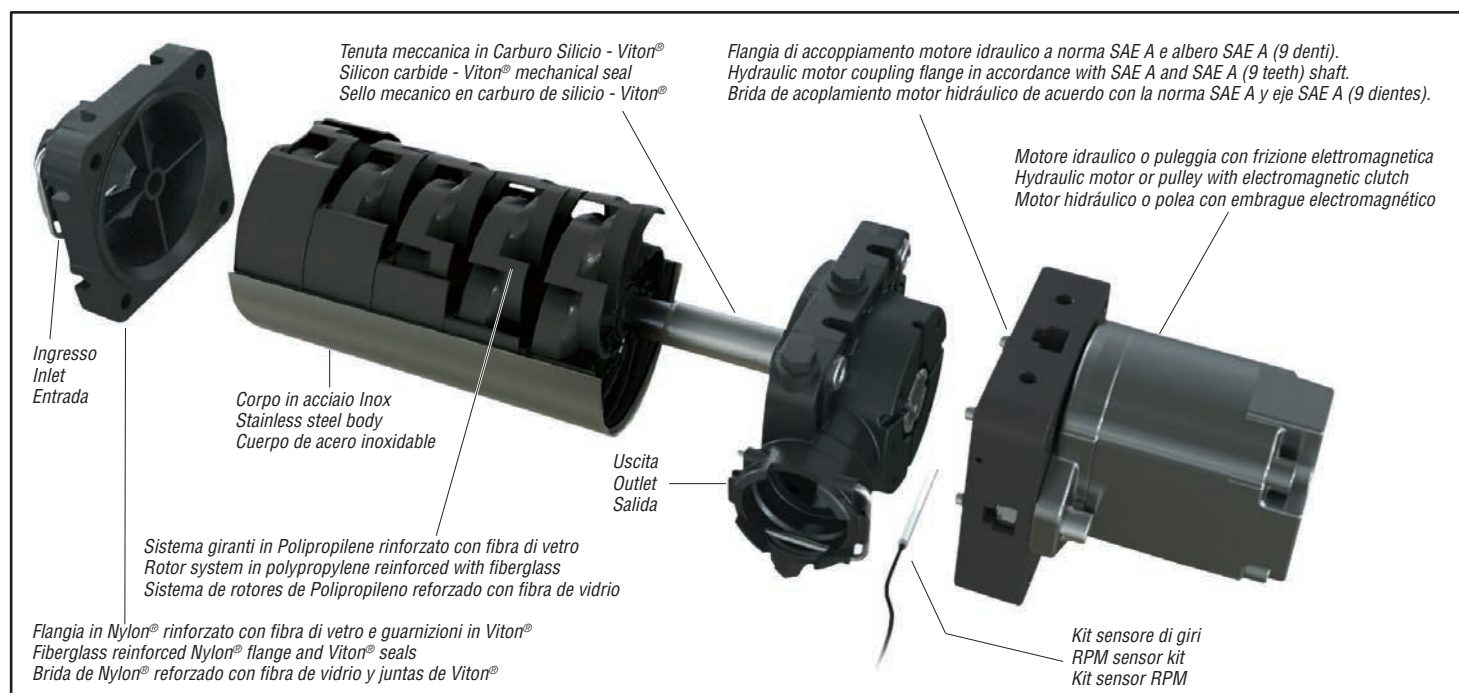

Le pompe serie MSP sono dotate di un sistema di aggancio tramite piastra che ne permette il fissaggio in qualunque posizione, anche in spazi ridotti.

The MSP series pumps are equipped with a coupling system through plate allowing the fixing in any position, even in small places.

Las bombas serie MSP están equipadas con un sistema de acoplamiento a través de la placa que permite la fijación en cualquier posición, también en lugares reducidos.



Dima di attacco

Attachment template

Plantilla de empalme

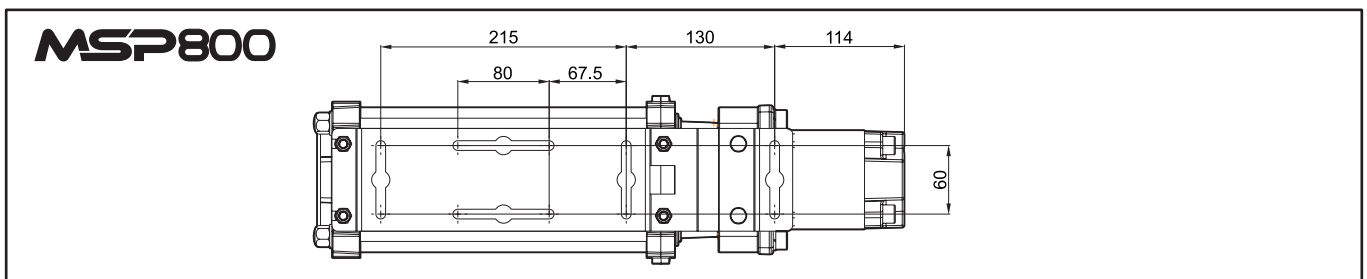
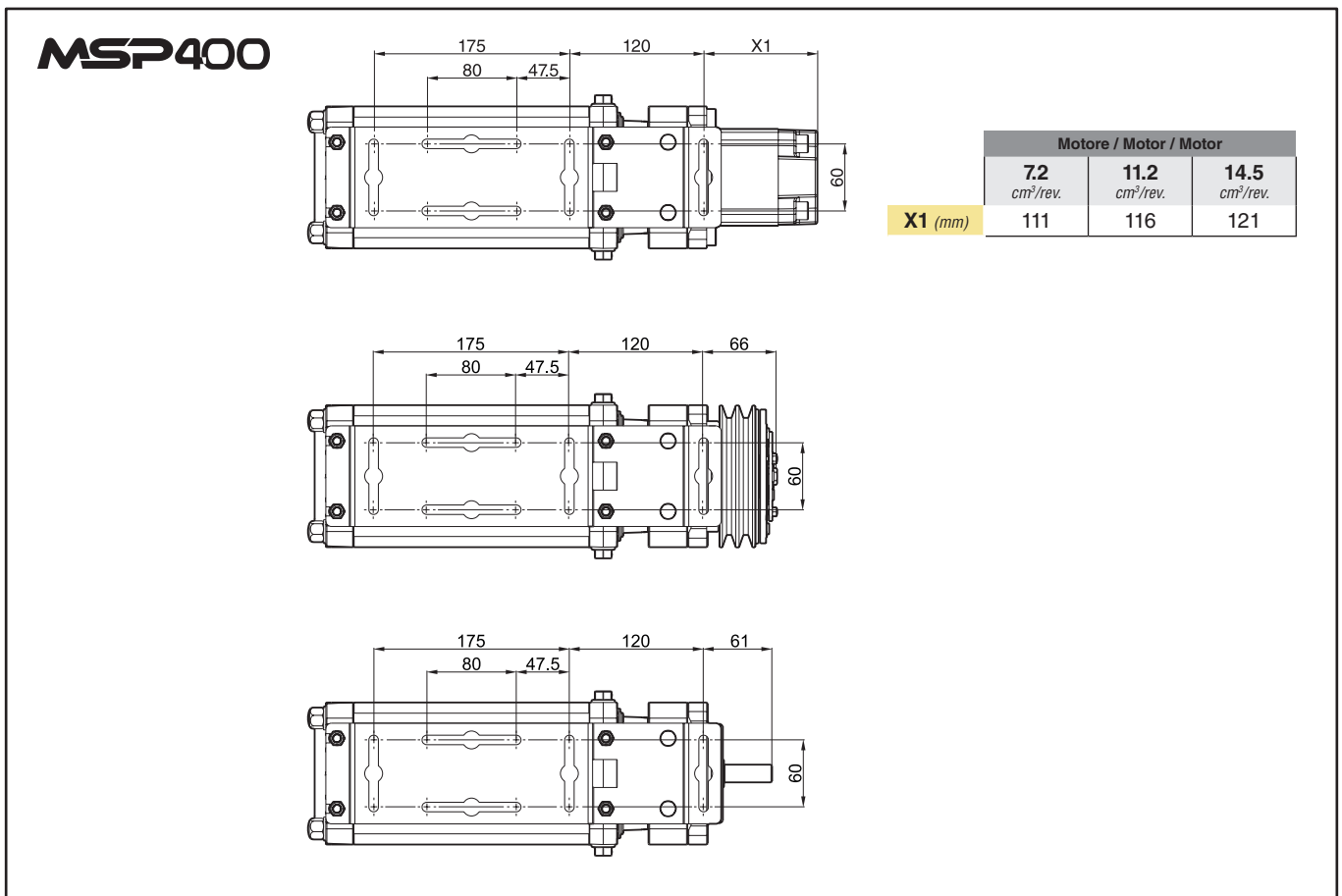

**POMPE CENTRIFUGHE MULTISTADIO  
MULTISTAGE CENTRIFUGAL PUMPS  
BOMBAS CENTRÍFUGAS MULTIETAPAS**

# MSP400

- **Sistema giranti in Polipropilene rinforzato con fibra di vetro**
- Elevata efficienza (bassa portata d'olio).
- Ingombri ridotti.
- Portata 400 l/min @ 8 bar (4200 giri/min).
- Ottima resistenza chimica.
- Direzione del raccordo di uscita indipendente dalla posizione di fissaggio.
- **Rotor system in polypropylene reinforced with fiberglass**
- High efficiency (low oil flow).
- Reduced size.
- Flow rate 400 l/min @ 8 bar - 103 GPM @ 120 PSI (4200 RPM).
- Excellent chemical compatibility.
- Direction of output adapter independent from mounting position.
- **Sistema de rotores de Polipropileno reforzado con fibra de vidrio**
- Alto rendimiento (bajo flujo de aceite).
- Tamaño compacto.
- Caudal 400 l/min a 8 bar (4200 RPM).
- Excelente resistencia química.
- Gestión de la conexión de salida independiente de la posición de fijación.

Le pompe serie MSP400 Sono disponibili con attacco a forchetta T6 (A), con attacco filettato GAS e NPT (B) e con adattatore flangiato per attacco a morsetto\* (C).

The MSP400 series pumps are available with T6 fork connection (A), with GAS and NPT thread (B) and with clamp connection\* (C).

Las bombas serie MSP400 están disponibles con conexión de horquilla T6 (A), con rosca GAS y NPT (B) y con toma de mordaza\* (C).

\*: Compatible con attacchi tipo Banjo®, Hypro® e Bee Valve®.  
Suitable for use with Banjo®, Hypro® and Bee Valve® connections.  
Compatible con las conexiones tipo Banjo®, Hypro® y Bee Valve®.

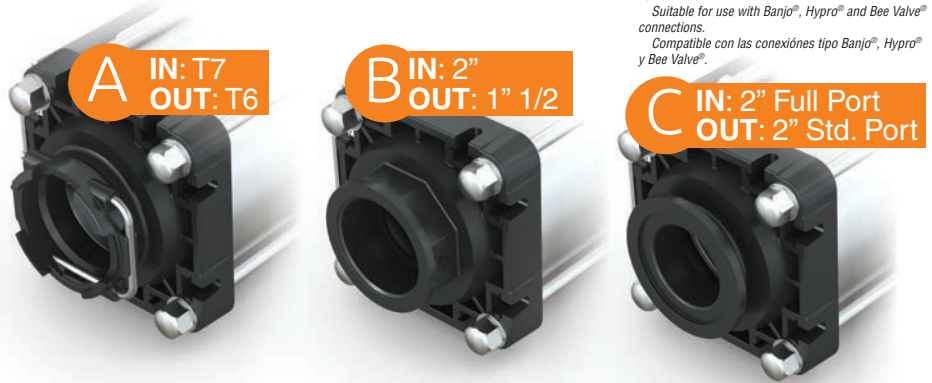

**IMPORTANTE! - IMPORTANT! - ¡IMPORTANTE!**

Raccordi di completamento con attacco a forchetta da ordinare **SEPARATAMENTE** dal capitolo "FITTINGS"

End fork fittings must be ordered **SEPARATELY** in the chapter "FITTINGS"

Empalmes de terminación con toma de horquilla deben pedirse **POR SEPARADO** a la sección "FITTINGS"

**Con motore idraulico / With hydraulic motor / Con motor hidráulico**



Attacco / Connection / Conexión				Portata acqua MAX Water MAX flow MAX caudal agua		Pressione acqua MAX Water MAX pressure MAX presión agua		Portata olio MAX Oil MAX flow MAX caudal aceite		Pressione olio MAX Oil MAX pressure MAX presión aceite		Motore Motor Motor				
A	B	B	C	l/min	GPM	bar	PSI	l/min	GPM	bar	PSI					
Forchetta Fork Horquilla	Filetto Thread Rosca (BSP)	Filetto Thread Rosca (NPT)	Morsetto Clamp Mordaza	970 05221	970 05222	970 05223	970 05224	517	137	7.5	109	26.5	7	135	1955	7.2
				970 05201	970 05202	970 05203	970 05204	560	148	10.6	154	49.2	13	120	1735	11.2
				970 05231	970 05232	970 05233	970 05234	567	150	11.0	160	64.3	17	106	1537	14.5

**Con puleggia\*\* a frizione elettromagnetica / With electromagnetic clutch pulley\*\* / Con polea\*\* a embrague electromagnético**



Attacco / Connection / Conexión				Portata acqua MAX Water MAX flow MAX caudal agua		Pressione acqua MAX Water MAX pressure MAX presión agua		Potenza MAX assorb. MAX absorption Potencia MAX absorb.		Alimentazione Power supply Alimentación		Puleggia ELM ELM pulley Polea ELM			
A	B	B	C	l/min	GPM	bar	PSI	kW	Volt	Amp					
Forchetta Fork Horquilla	Filetto Thread Rosca (BSP)	Filetto Thread Rosca (NPT)	Morsetto Clamp Mordaza	970 55201	970 55202	970 55203	970 55204	567	150	11.0	160	8.2	12 Vdc	4	127

\*\* : a doppia gola per cinghie trapezoidali tipo SPA 12,7x10 secondo DIN 7753/1 - ISO-R459-460 oppure A 13x8 secondo UNI 5265 - ISO 4183 - DIN 2215.  
\*\* : double groove pulley for V-belts as SPA 12,7X10 in accordance to DIN 7753/1 - ISO-R459-460 or A 13x8 in accordance to UNI 5265 - ISO 4183 - DIN 2215  
\*\* : Polea de doble canal para correas trapezoidales como SPA 12,7X10 conforme a DIN 7753/1 - ISO-R459-460 o A 13x8 conforme a UNI 5265 - ISO 4183 - DIN 2215

**Con attacco diretto al pignone / With direct attachment to the sprocket / Con empalme directo al piñón**



Attacco / Connection / Conexión				Portata acqua MAX Water MAX flow MAX caudal agua		Pressione acqua MAX Water MAX pressure MAX presión agua		Potenza MAX assorb. MAX absorption Potencia MAX absorb.					
A	B	B	C	l/min	GPM	bar	PSI	kW					
Forchetta Fork Horquilla	Filetto Thread Rosca (BSP)	Filetto Thread Rosca (NPT)	Morsetto Clamp Mordaza	970 45201	970 45202	970 45203	970 45204	567	150	11.0	160	8.2	



Dimensioni

Dimensions

Dimensiones

Con motore idraulico / With hydraulic motor / Con motor hidráulico

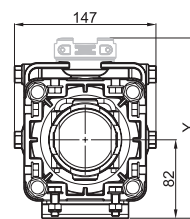
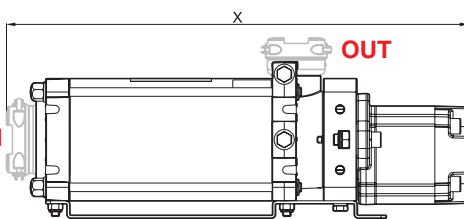
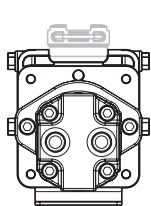

X (mm)				
Attacco / Connection / Conexión				
	A	B	B	C
	Forchetta Fork Horquilla	Filetto Thread Rosca (BSP)	Filetto Thread Rosca (NPT)	Morsetto Clamp Mordaza
Motore Motor Motor	7.2 cm <sup>3</sup> /rev.	475	469	463
	11.2 cm <sup>3</sup> /rev.	480	474	468
	14.5 cm <sup>3</sup> /rev.	485	479	473

Y (mm)				
Attacco / Connection / Conexión				
	A	B	B	C
	Forchetta Fork Horquilla	Filetto Thread Rosca (BSP)	Filetto Thread Rosca (NPT)	Morsetto Clamp Mordaza
	188	180	180	180

	Con motore / With motor / Con motor	7.2 cm <sup>3</sup> /rev.	11.2 cm <sup>3</sup> /rev.	14.5 cm <sup>3</sup> /rev.
Peso della pompa Pump weight Peso de la bomba (kg)		9,6	9,8	10

Con puleggia a frizione elettromagnetica / With electromagnetic clutch pulley / Con polea a embrague electromagnético

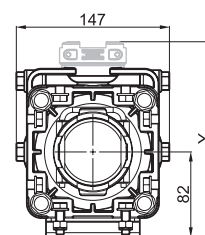
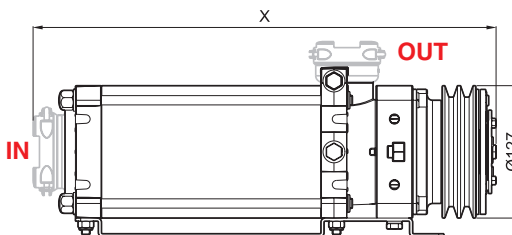
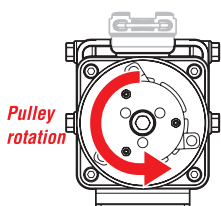

Attacco / Connection / Conexión				
	A	B	B	C
	Forchetta Fork Horquilla	Filetto Thread Rosca (BSP)	Filetto Thread Rosca (NPT)	Morsetto Clamp Mordaza
X (mm)	452	446	446	440
Y (mm)	188	180	180	180

Peso della pompa Pump weight Peso de la bomba (kg)	11,5
---	------

Con attacco diretto al pignone / With direct attachment to the sprocket / Con empalme directo al piñón

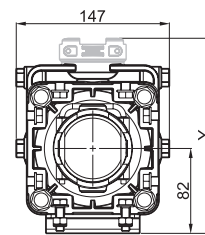
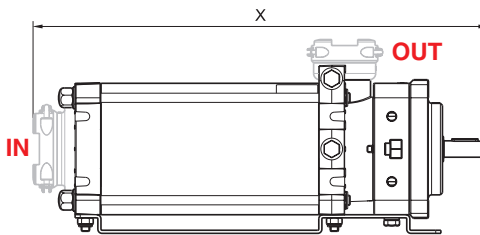
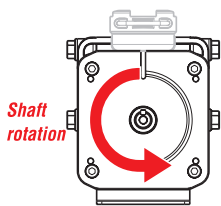

Attacco / Connection / Conexión				
	A	B	B	C
	Forchetta Fork Horquilla	Filetto Thread Rosca (BSP)	Filetto Thread Rosca (NPT)	Morsetto Clamp Mordaza
X (mm)	440	434	434	428
Y (mm)	188	180	180	180

Peso della pompa Pump weight Peso de la bomba (kg)	8,7
---	-----

**Prestazioni**

**Performances**

**Rendimientos**

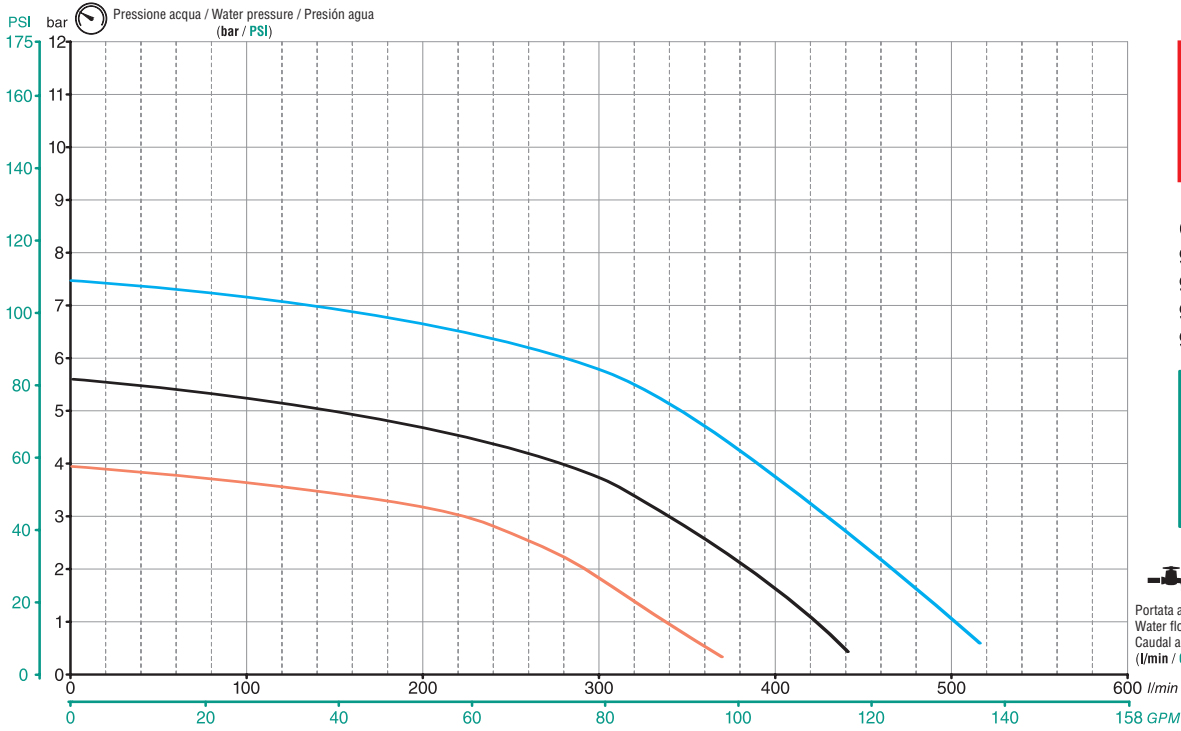

**Motore  
Motor  
Motor** **7.2**  
*cm³/rev.*

**COD.:**  
97005221  
97005222  
97005223  
97005224

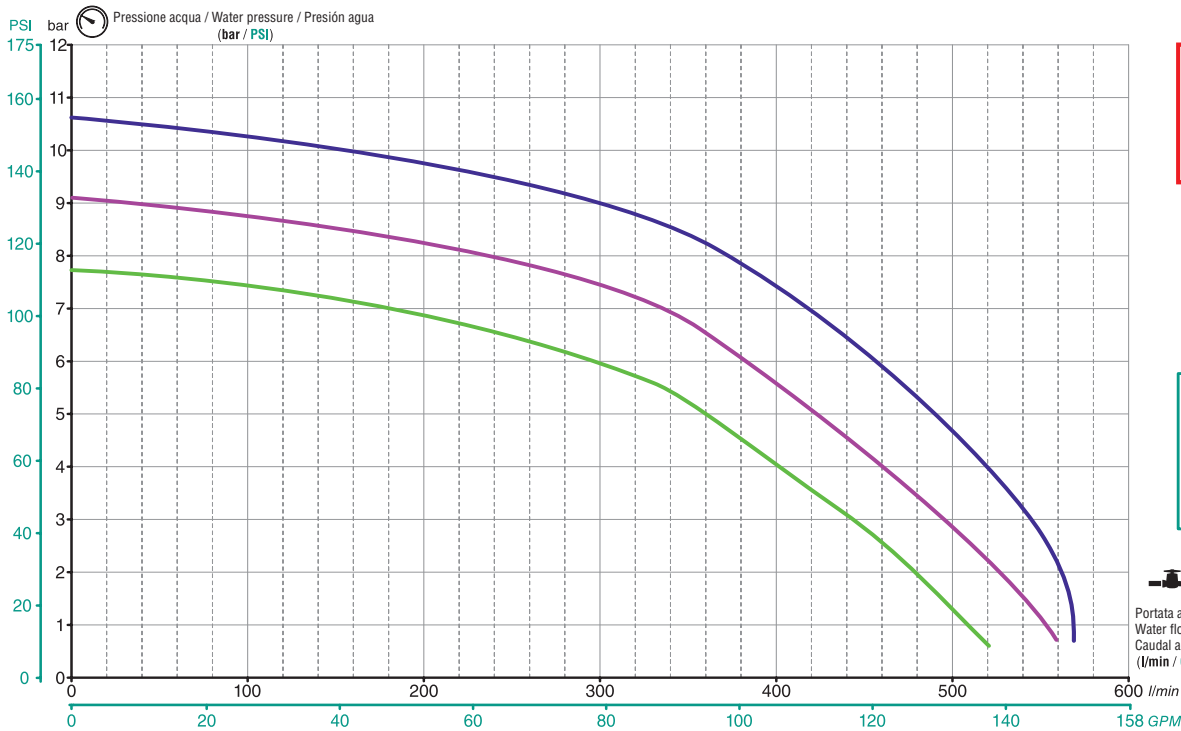

**Motore  
Motor  
Motor** **11.2**  
*cm³/rev.*

**COD.:**  
97005201  
97005202  
97005203  
97005204

Prestazioni

Performances

Rendimientos

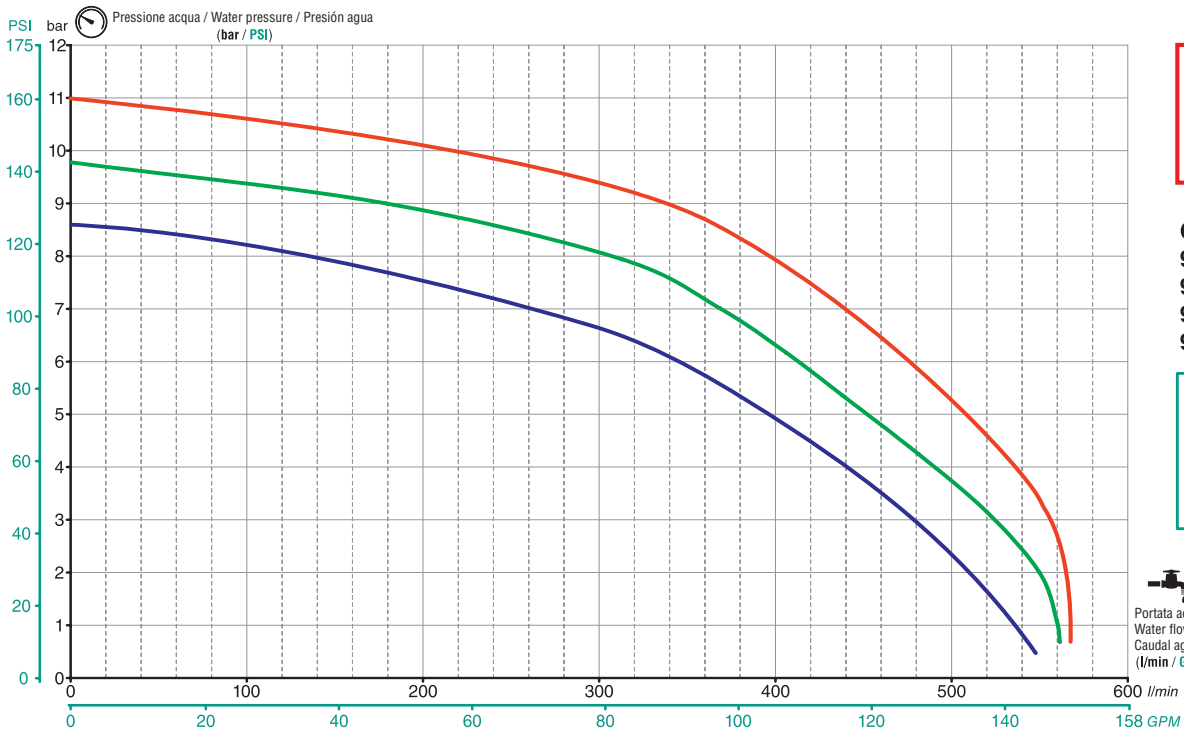

**Motore**  
**Motor**  
**Motor**

**14.5**  
*cm³/rev.*

COD.:  
97005231  
97005232  
97005233  
97005234

Portata olio / Oil flow / Caudal aceite

- 64,3 l/min - 17 GPM
- 60,5 l/min - 16 GPM
- 56,8 l/min - 15 GPM

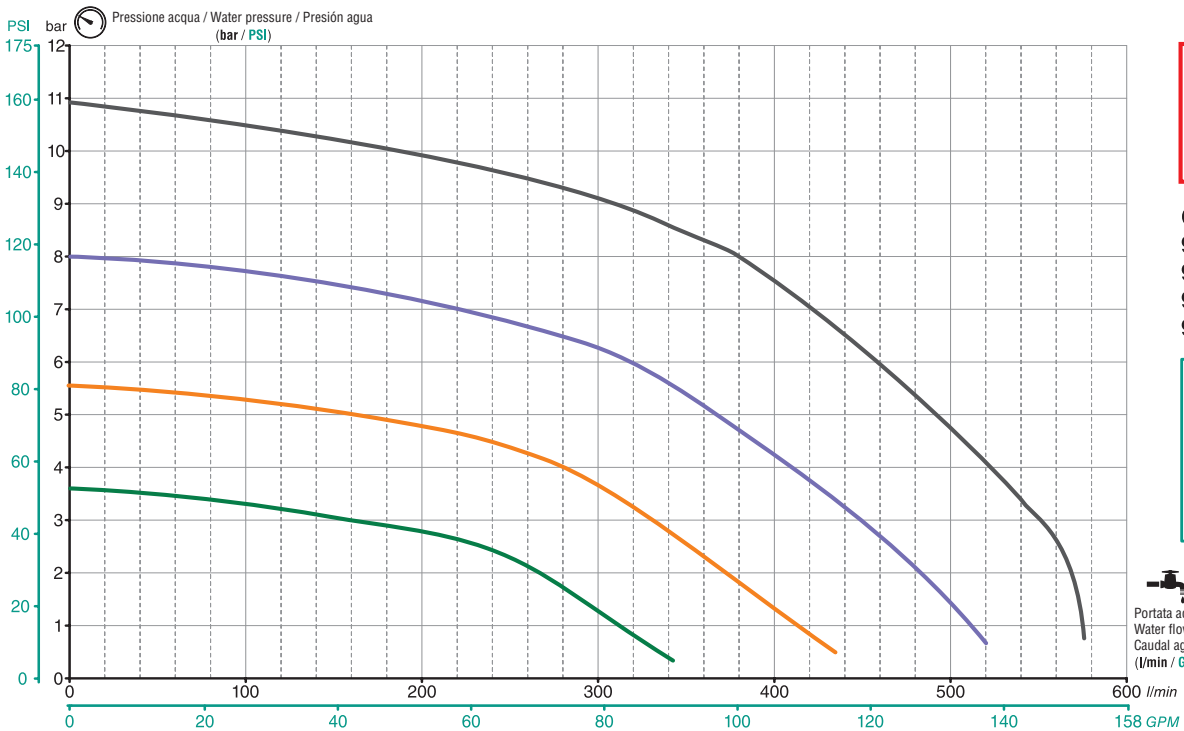
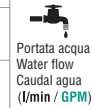

**Puleggia**  
**Pulley**  
**Polea**

COD.:  
97055201  
97055202  
97055203  
97055204

RPM puleggia / Pulley RPM / RPM polea

- 4200 RPM
- 3600 RPM
- 3000 RPM
- 2400 RPM

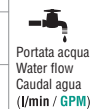

**POMPE CENTRIFUGHE MULTISTADIO  
MULTISTAGE CENTRIFUGAL PUMPS  
BOMBAS CENTRÍFUGAS MULTIETAPAS**

# MSP800

- **Sistema giranti in Polipropilene rinforzato con fibra di vetro**
- Elevata efficienza (bassa portata d'olio).
- Ingombri ridotti.
- Portata 800 l/min @ 7 bar (4200 giri/min).
- Ottima resistenza chimica.
- Direzione del raccordo di uscita indipendente dalla posizione di fissaggio.
- **Rotor system in polypropylene reinforced with fiberglass**
- High efficiency (low oil flow).
- Reduced size.
- Flow rate 800 l/min @ 7 bar - 210 GPM @ 100 PSI (4200 RPM).
- Excellent chemical compatibility.
- Direction of output adapter independent from mounting position.
- **Sistema de rotores de Polipropileno reforzado con fibra de vidrio**
- Alto rendimiento (bajo flujo de aceite).
- Tamaño compacto.
- Caudal 800 l/min a 7 bar (4200 RPM).
- Excelente resistencia química.
- Gestión de la conexión de salida independiente de la posición de fijación.



Le pompe serie MSP800 Sono disponibili con attacco a forchetta (A) e con adattatore flangiato per attacco a morsetto\* (B).  
The MSP800 series pumps are available with fork connection (A) and with clamp connection\* (B).  
Las bombas serie MSP800 están disponibles con conexión de horquilla (A) y con toma de mordaza\* (B).

**A** IN: T9  
OUT: T7



**B** IN: 3"  
OUT: 2" Full Port

\*: Compatibile con attacchi tipo Banjo®, Hypro® e Bee Valve®.  
Suitable for use with Banjo®, Hypro® and Bee Valve® connections.  
Compatible con las conexiones tipo Banjo®, Hypro® y Bee Valve®.

### IMPORTANTE! - IMPORTANT! - ¡IMPORTANTE!

**!** Raccordi di completamento con attacco a forchetta da ordinare **SEPARATAMENTE** dal capitolo "FITTINGS"

End fork fittings must be ordered **SEPARATELY** in the chapter "FITTINGS"

Empalmes de terminación con toma de horquilla deben pedirse **POR SEPARADO** a la sección "FITTINGS"





Con motore idraulico / With hydraulic motor / Con motor hidráulico

Attacco / Connection / Conexión		Portata acqua MAX Water MAX flow MAX caudal agua		Pressione acqua MAX Water MAX pressure MAX presión agua		Portata olio MAX Oil MAX flow MAX caudal aceite		Pressione olio MAX Oil MAX pressure MAX presión aceite		Motore Motor Motor
A	B									
Forchetta Fork Horquilla	Morsetto Clamp Mordaza	I/min	GPM	bar	PSI	I/min	GPM	bar	PSI	cm <sup>3</sup> /rev.
<b>971 04241</b>	<b>971 04244</b>	960	255	12	175	83	22	155	2250	19

Dimensioni e peso

Dimensions and weight

Dimensiones y peso

Peso della pompa  
Pump weight  
Peso de la bomba  
(kg) **11**

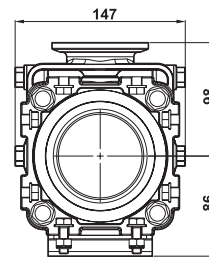
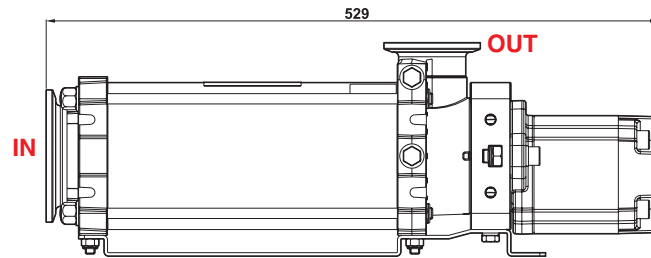
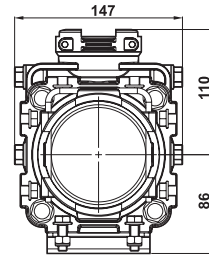
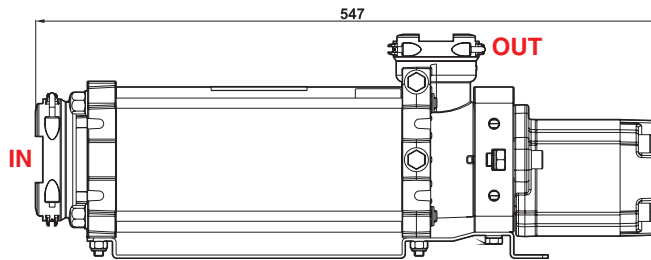

Prestazioni

Performances

Rendimientos

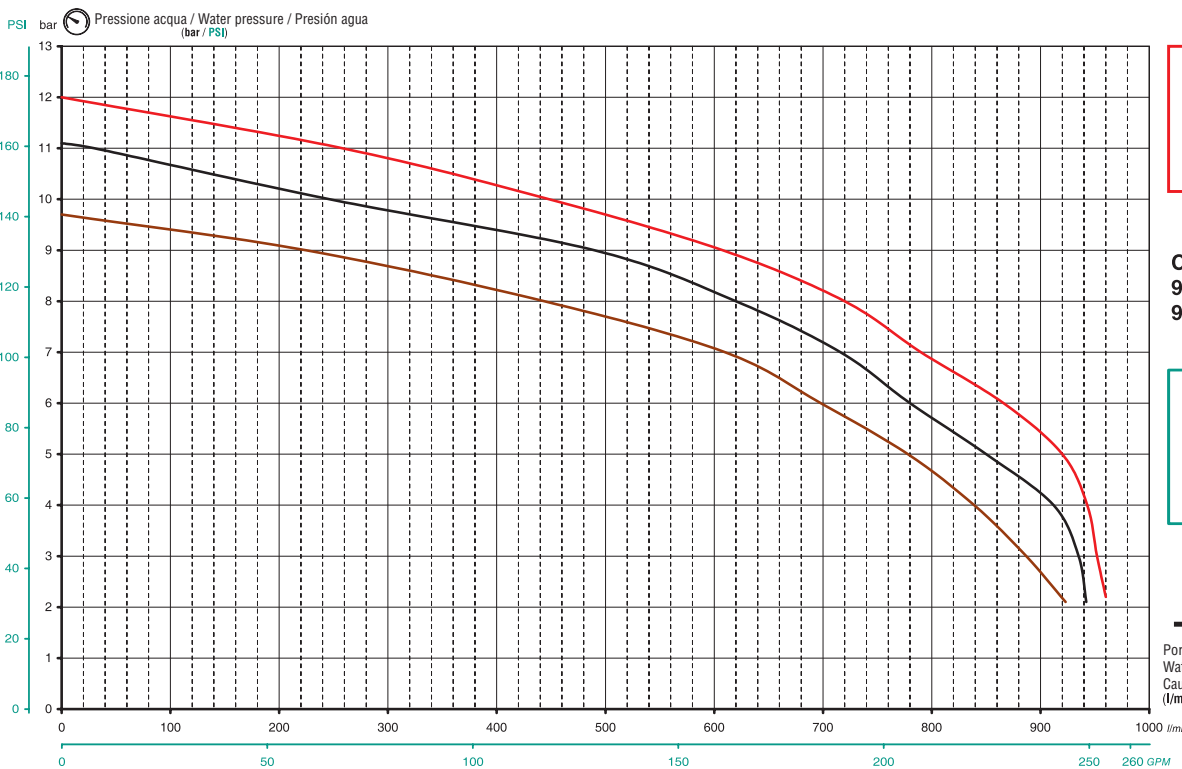

**Motore  
Motor  
Motor** **19**  
cm<sup>3</sup>/rev.

**COD.:**  
**97104241**  
**97104244**

Portata olio / Oil flow / Caudal aceite

- 83,3 l/min - 22 GPM
- 79,4 l/min - 21 GPM
- 75,7 l/min - 20 GPM

Portata acqua  
Water flow  
Caudal agua  
(l/min / GPM)

**ACCESSORI PER POMPE CENTRIFUGHE MULTISTADIO**  
**ACCESSORIES FOR MULTISTAGE CENTRIFUGAL PUMPS**  
**ACCESORIOS PARA BOMBAS CENTRÍFUGAS MULTITETAPAS**

**MSP**  
SERIES

**Kit sensore di giri**

- Cavo lunghezza 20cm.
- Segnale di uscita NPN
- Tensione di alimentazione 12Vdc.

**RPM sensor kit**

- 20 cm cable
- NPN output signal
- Power supply 12 Vdc.

**Kit sensor RPM**

- Cable long. 20cm.
- Signal de salida NPN
- Alimentación 12Vdc.



COD.  
CODE  
CÓD.

970 000.500

**MSP400**  
**MSP800**

**Kit valvola unidirezionale per motore idraulico**

Valvola unidirezionale da installare sul motore idraulico delle pompe centrifughe serie MSP400, nel condotto di scarico.

- Protegge il motore da rotture nel caso di errato collegamento dei tubi olio (inversione della mandata con lo scarico).
- Attacco G 3/4".
- Completa di guarnizioni.

**Single-acting valve kit for hydraulic motor**

Single-acting valve to be installed to the hydraulic motor, in the drain pipe of the MSP400 series centrifugal pumps.

- It protects the motor from failure in case of wrong connection of the oil pipes (inversion of the drain and delivery pipes).
- 3/4" G coupling.
- Complete with seals.

**Kit válvula unidireccional para motor hidráulico**

Válvula unidireccional para instalar en el motor hidráulico de las bombas centrífugas serie MSP400, en el conducto de descarga.

- Protege el motor de roturas en caso de conexión incorrecta de los tubos de aceite (inversión de impulsión con la descarga).
- Empalme G 3/4".
- Juntas incluidas.



COD.  
CODE  
CÓD.

970 001

**MSP400**



**NIAGARA** è un premiscelatore (mixer) per macchine da diserbo, progettato per ottenere la massima versatilità e adattabilità su tutti i tipi di macchine, indipendentemente dalla tipologia di pompa utilizzata e dalla sua dislocazione sulla macchina agricola. Ogni componente è stato studiato appositamente per questo utilizzo così da ottenere un accessorio affidabile e performante, garanzia di una perfetta miscelazione dei composti chimici, di un accurato lavaggio senza residui e di un'elevata velocità di trasferimento del prodotto miscelato.

**NIAGARA** is a mixer for crop sprayers and has been designed to gain the maximum level of versatility and adaptability on all machine types, regardless of the type of pump used and of its position on the farming machine. Every part has been conceived for this use in order to have a reliable and performing accessory which ensures a perfect mixing of the chemical compounds, a thorough cleaning of all residues and a high transfer speed of the mixed product.

**NIAGARA** es un pre-mezclador (mixer) para máquinas para tratamiento con barras, para obtener la máxima versatilidad y adaptabilidad en todos los tipos de máquinas, independientemente del tipo de bomba utilizada y de su posición en la máquina agrícola. Cada componente ha sido estudiado específicamente para este uso, para obtener un accesorio confiable y eficiente, dando garantía de un perfecto mezclado de los compuestos químicos, un cuidadoso lavado sin residuos y una elevada velocidad de transferencia del producto mezclado.



30 lt  
8 gal

20 lt  
5 gal

COD. CODE CÓD.	Tipo Type Tipo	A mm	B mm	C mm	Peso Weight Peso
503 3301	30 l / 8 gal	575	618	542	10 kg
503 3201	20 l / 5 gal	487	612	462	8 kg

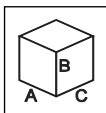

Kit di aspirazione per prelevare i prodotti chimici direttamente dal contenitore

Suction kit to extract the chemicals directly from the tank

Kit de aspiración para extraer los productos químicos directamente del contenedor

COD. CODE CÓD.	Lungh. Length Long.
503 3000	1,5 m

Per - For - Para  
cod. 5033201 - 5033301





# MIXER ECOLOGICO ECOLOGICAL MIXER MIXER ECOLOGICO

# NIAGARA

- Sistema di aspirazione Venturi integrato nella valvola di scarico, per un ingombro ridotto.
- Profilo e superficie della cisterna ottimizzati per facilitare il risciacquo ed evitare ristagni dei prodotti chimici.
- Fornito con 3 differenti ugelli venturi per adattarlo ad ogni tipologia di pompa.
- Sonda di aspirazione per prelevare i prodotti chimici direttamente dal contenitore (da ordinare separatamente).
- Ugello speciale per miscelazione, adatto anche a prodotti granulari o in polvere.
- Getto rotante per il lavaggio dei contenitori dei prodotti chimici.
- Telaio portante in acciaio con trattamento di cataforesi.
- Maniglia di sollevamento integrata.
- Coperchio Ø 455 mm (mod. 30 lt.), Ø 355 mm (mod. 20 lt.), per facilitare l'immissione di prodotti chimici.
- Serbatoio in polietilene.

- Venturi suction system integrated with drain valve, for reduced overall dimensions.
- Tank profile and surface optimized to facilitate rinsing and avoid chemical product stagnation.
- Supplied with 3 different Venturi nozzles to adapt it to every type of pump.
- Suction probe to collect chemical products directly from the container (to be ordered separately).
- Mixing special nozzle, suitable also for granular or powder products.
- Rotating nozzle for chemicals tank cleaning.
- Steel bearing frame with cathaphoresis treatment.
- Integrated lifting handle.
- Ø 455 mm lid (in mod. 30 l), Ø 355 mm lid (in mod. 20 l) to facilitate chemical product inlet.
- Polyethylene tank

- Sistema de aspiración Venturi integrado en la válvula de descarga, para ocupar menos espacio.
- Perfil y superficie de la cisterna optimizados para facilitar el enjuague y evitar estancamientos de los productos químicos.
- Suministrado con 3 diferentes boquillas para adaptarlo a todo tipo de bomba.
- Sonda de aspiración para extraer los productos químicos directamente del contenedor (para pedir por separado).
- Boquilla especial para mezclado, adecuada también para productos granulados o en polvo.
- Boquilla rotativa para el enjuague de los contenedores de productos químicos.
- Bastidor portante de acero con tratamiento de cataforesis.
- Manija para levantar integrada.
- Tapa de Ø 455 mm (mod. 30 l), Ø 355 mm (mod. 20 l) para facilitar la introducción de productos químicos.
- Tanque de polietileno

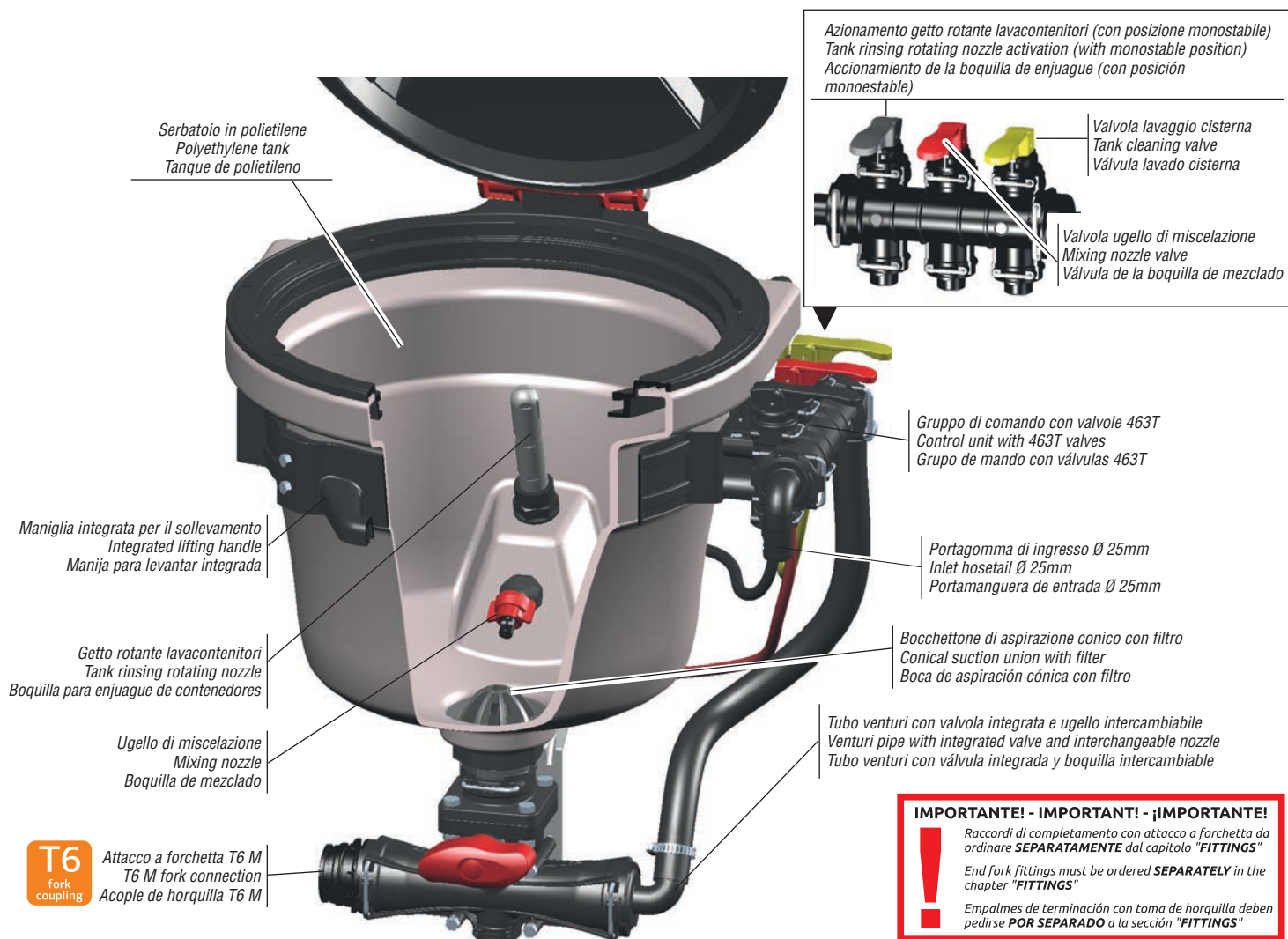

### IMPORTANT! - IMPORTANT! - ¡IMPORTANT!

Raccordi di completamento con attacco a forchetta da ordinare **SEPARATEMENTE** dal capitolo "FITTINGS"

End fork fittings must be ordered **SEPARATELY** in the chapter "FITTINGS"

Empalmes de terminación con toma de horquilla deben pedirse **POR SEPARADO** a la sección "FITTINGS"

## Dati tecnici Technical data Datos tecnicos

20 lt / 5 gal 30 lt / 8 gal Per - For - Para cod. 5033201 - 5033301

Ugello 5 mm - 5 mm nozzle - Boquilla 5 mm		
Pressione Pressure Pression	Portata Ugello Nozzle flow Caudal boquilla	Svuotamento Eduction Carga
bar PSI	(l/min)	(l/sec)
2	29	2,2
3	44	2,7
4	58	3,4
5	73	4,0
6	87	4,7
7	102	5,2
8	116	5,5

20 lt / 5 gal 30 lt / 8 gal Per - For - Para cod. 5033201 - 5033301

Ugello 8 mm - 8 mm nozzle - Boquilla 8 mm			
Pressione Pressure Pression	Portata Ugello Nozzle flow Caudal boquilla	Svuotamento Eduction Carga	
bar PSI	(l/min)	(l/sec)	
2	29	60	2,0
3	44	74	2,6
4	58	85	3,3
5	73	95	4,1
6	87	100	4,8
7	102	110	5,3
8	116	120	5,8

30 lt / 8 gal Per - For - Para cod. 5033301

Ugello 11 mm - 11 mm nozzle - Boquilla 11 mm			
Pressione Pressure Pression	Portata Ugello Nozzle flow Caudal boquilla	Svuotamento Eduction Carga	
bar PSI	(l/min)	(l/sec)	
2	29	125	2,5
3	44	150	2,8
4	58	170	3,2
5	73	182	3,6
6	87	195	4,0
7	102	212	4,3



Sistema di caricamento con attacco a forchetta T6 con valvola a sfera di intercettazione

Filling system with T6 fork coupling with shut-off ball valve

Sistema de carga con empalme de horquilla T6 con válvula de bola de interceptación

**T6**  
fork  
coupling



COD. CODE CÓD.	Colore ugello Nozzle colour Color boquilla	Ø ugello Nozzle Ø Ø boquilla
▶ 453 M01.004		5 mm
453 M01.001		8 mm
453 M01.002		11 mm

Dati tecnici e portate degli ugelli a pag. G-12

Technical data and nozzles flows at page G-12

Datos técnicos y caudales de las boquillas a la pag. G-12

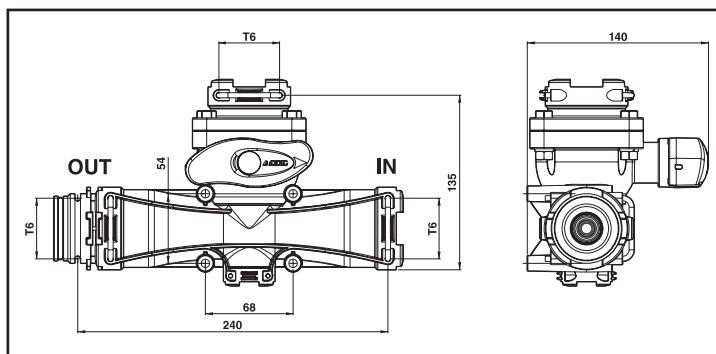

**IMPORTANT! - IMPORTANT! - ¡IMPORTANT!**



Raccordi di completamento con attacco a forchetta da ordinare **SEPARATAMENTE** dal capitolo "FITTINGS"

End fork fittings must be ordered **SEPARATELY** in the chapter "FITTINGS"

Empalmes de terminación con toma de horquilla deben pedirse **POR SEPARADO** a la sección "FITTINGS"

Sistema di caricamento con attacco a forchetta T6 senza valvola di intercettazione

Filling system with T6 fork coupling without shut-off valve

Sistema de carga con empalme de horquilla T6 sin válvula de interceptación

**T6**  
fork  
coupling



COD. CODE CÓD.	Colore ugello Nozzle colour Color boquilla	Ø ugello Nozzle Ø Ø boquilla
▶ 503 3001.004		5 mm
503 3001.001		8 mm
503 3001.002		11 mm

Dati tecnici e portate degli ugelli a pag. G-12

Technical data and nozzles flows at page G-12

Datos técnicos y caudales de las boquillas a la pag. G-12

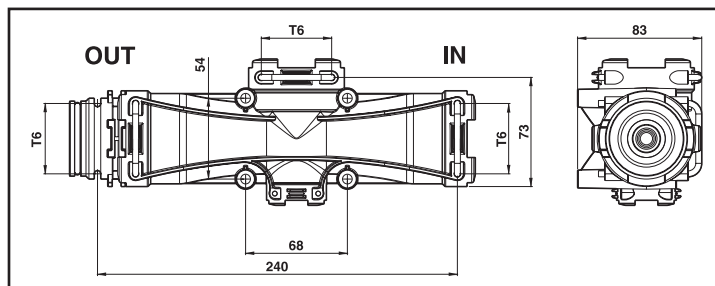

# ACCESSORI ACCESSORIES ACCESORIOS

## Gruppo servizi a 3 vie

- Struttura in PA 6 rinforzato con fibra di vetro.
- Attacchi a forchetta T5 Maschio/Femmina.
- Uscita valvole con innesti rapidi per tubo D=10mm.
- Particolari interni in acciaio Inox AISI 303.
- Guarnizioni in viton.
- Maniglie del gruppo colorate per le differenti operazioni.

## 3-way service unit

- Structure in fiber glass reinforced PA 6.
- Male/Female T5 fork couplings.
- Valve output with quick-couplings for pipe D=10mm.
- Internal parts in AISI 303 stainless steel. Seals in Viton.
- Colored unit handles for different operations.

## Grupo servicios de 3 vías

- Estructura de PA 6 reforzada con fibra de vidrio.
- Empalmes de horquilla T5 Macho/Hembra.
- Salida válvulas con acopl. rápidos para tubo D=10mm.
- Componentes internos de acero Inox AISI 303.
- Juntas de viton.
- Manijas del grupo de varios colores para las diferentes operaciones.

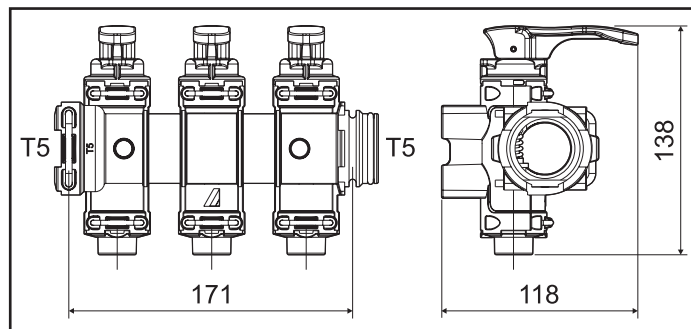

COD.  
CODE  
CÓD.  
**463 TM5301**

**T5**  
fork  
coupling

### ! IMPORTANTE! - IMPORTANT! - ¡IMPORTANTE!

Raccordi di completamento con attacco a forchetta da ordinare **SEPARATAMENTE** dal capitolo "FITTINGS"

End fork fittings must be ordered **SEPARATELY** in the chapter "FITTINGS"

Empalmes de terminación con toma de horquilla deben pedirse **POR SEPARADO** a la sección "FITTINGS"

## Bocchettone di scarico

- Studiata per il kit di aspirazione cod. 5033000.
- Attacco a forchetta T6

## Drain outlet

- Designed for suction kit code 5033000.
- T6 fork coupling.

## Boca de descarga

- Estudiada para el kit de aspiración cód. 5033000.
- Empalme de horquilla T6.

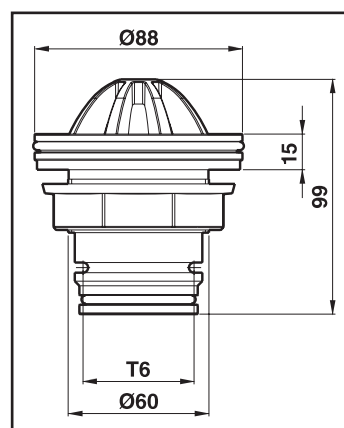

COD.  
CODE  
CÓD.  
**503 3301.500**

**T6**  
fork  
coupling

- Serbatoio di nuova concezione realizzato in polietilene ad alta resistenza
- Cestello di contenimento rinforzato
- Nuova piastra di fissaggio del gruppo compressore
- Nuovi diffusori verticali e orizzontali



- Può essere montato su tutte le macchine da diserbo e da semina
- Elimina il rischio di sovradosaggio o di assenza di trattamento su strisce di coltura
- Diffusore ad alta produzione di schiuma a corpo unico, realizzato in EPDM, resistente agli urti accidentali dovuti ad irregolarità del terreno. Disponibile sia verticale che orizzontale.
- Tanica ad alta resistenza alla pressione
- Valvola di sicurezza collocata sul tappo del serbatoio prearata a 1 bar
- Lunghezza tubazioni 33 m
- Alimentazione 12 Vdc 9A

- New polyethylene highly resistant tank
- Reinforced basket
- New compressor assembly fastening plate
- New vertical and horizontal diffusers

- Suitable for all crop spraying and sowing machines.
- No more risks of overspraying or missing some crop areas.
- High foam single body production diffuser in EPDM and shock resistant in case of ground unevenness. Available both in vertical and horizontal version.
- High pressure resistant tank.
- Tank cap safety valve preset to 1 bar.
- Line length: 33 m
- 12 Vdc 9 A power supply

- Depósito de nueva concepción, realizado en polietileno de alta resistencia
- Cesta de contención reforzada
- Nueva placa de fijación del grupo compresor
- Nuevos difusores verticales y horizontales

- Se puede montar en todas las máquinas de pulverización y siembra
- Elimina el riesgo de dosaje excesivo o ausencia de tratamiento en franjas de cultivos
- Difusor con alta producción de espuma en cuerpo único, realizado en EPDM, resistente a los impactos accidentales debido a las irregularidades del terreno. Disponible vertical y horizontal.
- Tanque de alta resistencia a la presión
- Válvula de seguridad colocada en el tapón del depósito, pre-calibrada en 1 bar
- Longitud tubos 33 m
- Alimentación 12 Vdc 9A

COD. CODE Cód.	Comando Control unit Mando	Diffusore Nozzle Difusor	⚡
520005	Con scatola di comando <b>inclusa</b> Control box <b>included</b> Con caja de mando <b>incluida</b>		12 Vdc 9A
520005C	Per computer e scatole di comando serie 4669 Para ordenadores y cajas de mando serie 4669 For computers and control boxes series 4669		
5200052	Con scatola di comando <b>inclusa</b> Control box <b>included</b> Con caja de mando <b>incluida</b>		
5200052C	Per computer e scatole di comando serie 4669 Para ordenadores y cajas de mando serie 4669 For computers and control boxes series 4669		



COD. CODE Cód.	
520005.500	Kit fissaggio tanica Tank mounting kit Kit fijación bidón

# Da ordinare a parte  
To be order separately  
Se debe pedir por separado

Kit per il collegamento di un tracciabile standard (cod. 520005/5200052) ad un computer Bravo 300S, Bravo 180S o a una scatola di comando serie 4669.

Kit for connecting a standard foam marker (cod. 520005/5200052) to the Bravo 300S and Bravo 180S computers or to a control box series 4669.

Kit para conectar un marcador de espuma standard (cod. 520005/5200052) a un computador Bravo 300S o Bravo 180S o a una caja de mando serie 4669.

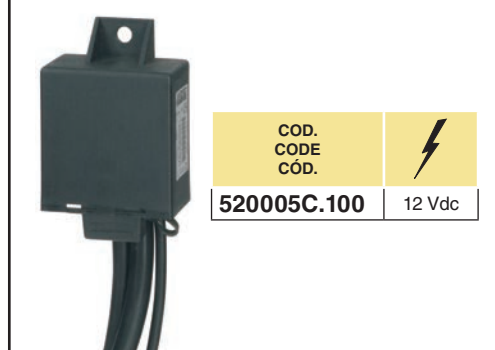

### Schiumogeno concentrato

Il prodotto schiumogeno inerte, di nuova formulazione, garantisce un miglior rendimento, una più lunga permanenza sul terreno e maggior visibilità in condizioni di semioscurità.

### Concentrated foam

The new-formula inert foaming product improves efficiency, lasts longer on the ground and offers greater visibility even in semi-dark conditions.

### Espumógeno concentrado

El producto espumógeno es inerte de nueva fórmula, garantiza un mejor rendimiento, una permanencia más larga en el terreno y mayor visibilidad en condiciones de semioscuridad.



COD. CODE Cód.	Contenuto Contents Contenido	Confezioni Packaging Embalajes
520050	5 lt / 1.32 US gall.	Tanica / Jerry-can / Lata
520035	25 lt / 6.6 US gall.	Tanica / Jerry-can / Lata
520033	200 kg / 441 lb	Barile / Barrel / Barril

# FLANGE PER ATOMIZZATORI E VALVOLA A SARACINESCA SPRAYER FLANGES AND GATE VALVE BRIDAS PARA ATOMIZADORES Y VALVULA DE COMPUERTA

## Flange per atomizzatori in Nylon® con guarnizione

Questi kit costituiti da due flange e da una guarnizione servono per bloccare il tubo per il passaggio del cardano alla cisterna. Sono standard per tutti i costruttori di cisterne.



## Nylon sprayer flanges with gasket

These kits, consisting of two flanges and one gasket, are designed to lock the hose to put the cardan through the tank. They are standardised for all tank manufacturers.

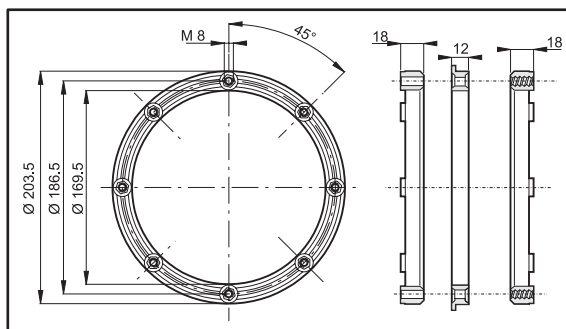

COD.  
CODE  
CÓD.

006 020

## Flange per atomizzatori in ottone con guarnizione

## Brass sprayer flanges with gasket

## Bridas para atomizadores de latón con junta

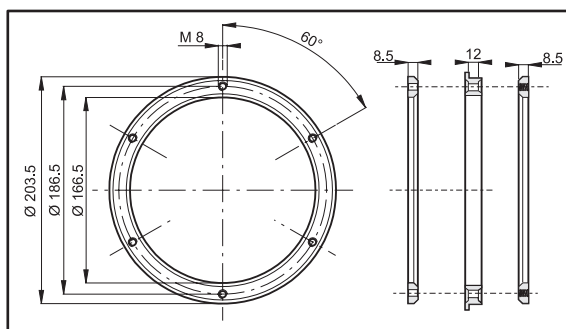

COD.  
CODE  
CÓD.

006 010

## Valvola a saracinesca

## Gate valve

## Válvula de compuerta

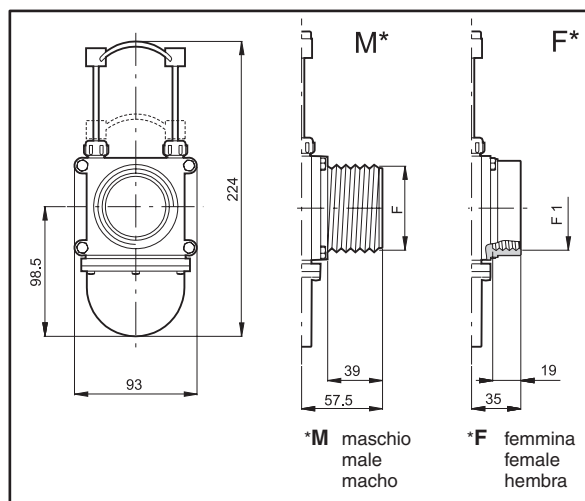

\*M maschio  
male  
macho

\*F femmina  
female  
hembra

COD. CODE CÓD.	F / F1 (BSP)	Tipo - Type - Tipo (* )
450 015	G1 1/4	M / M
450 016	G1 1/2	
450 017	G 2	M / F
450 025	G1 1/4	
450 026	G1 1/2	
450 027	G 2	F / F
450 035	G1 1/4	
450 036	G1 1/2	
450 037	G 2	



### Deviatore a 3 vie

- Corpo in polipropilene
- Leveraggio in acciaio inox
- Guarnizioni in Viton®
- Pressione di lavoro 2 bar

### 3-way by-pass

- Polypropylene body
- Stainless steel levers
- Gaskets made of Viton®
- Operating pressure 2 bar (30 psi)

### Desviador de 3 vías

- Cuerpo de polipropileno
- Palancas de acero inox
- Juntas de Viton®
- Presion de trabajo 2 bar



COD.  
CODE  
CÓD.  
**452 200**

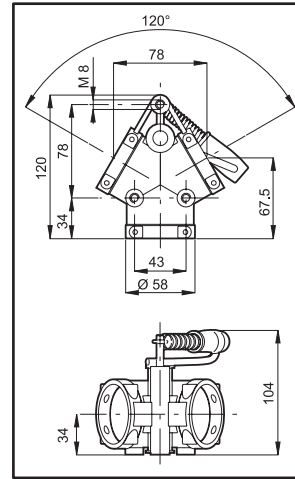

COD. CODE CÓD.	Ø (mm)	A (mm)	
<b>460 025</b>	25	39	10
<b>460 030</b>	30	39	10
<b>460 035</b>	35	39	10
<b>460 040</b>	40	39	10

COD. CODE CÓD.	Ø (mm)	A (mm)	B (mm)	
<b>460 135</b>	35	44	75	10
<b>460 140</b>	40	44	75	10

COD. CODE CÓD.	Ø (mm)	A (mm)	B (mm)	
<b>460 430</b>	30	31	52	10
<b>460 435</b>	35	31	55	10
<b>460 440</b>	40	31	60	10

COD. CODE CÓD.	Ø (mm)	A (mm)	B (mm)	
<b>460 250</b>	G 1 1/4	27	56	10
<b>460 260</b>	G 1 1/2	27	62	10

COD. CODE CÓD.	Ø (mm)	A (mm)	B (mm)	
<b>460 350</b>	G 1 1/4	34	46	10
<b>460 360</b>	G 1 1/2	39	50	10

COD. CODE CÓD.	
<b>460 300</b>	10

COD. CODE CÓD.	
<b>460 000.210</b>	50



# VALVOLA DI FONDO FOOT VALVE VALVULA DE FONDO

# 504

## Valvole di fondo

- Corpo in polipropilene rinforzato con fibra di vetro
- Otturatore in resina acetaleica
- Molla in acciaio INOX
- Guarnizioni in EPDM
- Pressione minima di apertura di 0.02 bar

## Foot valve

- Glass fiber reinforced polypropylene body
- Acetalc resin plug
- Stainless steel spring
- EPDM seals
- Minimum opening pressure 0.02 bar

## Valvulas de fondo

- Cuerpo de polipropileno reforzado con fibra de vidrio
- Obturador de resina acetálica
- Muelle de acero INOX
- Juntas de EPDM
- Presión mínima de apertura de 0,02 bar

## Valvola di fondo con attacco a forchetta maschio/maschio

## Foot valve with male/male fork connection

## Válvula de fondo con empalme con acople de horquilla macho/macho



COD. CODE CÓD.	T	L mm	X mm	 bar
504 201D	T5	69	77	7
504 201E	T6	72	77	
504 201F	T7	81	87	5
504 201H	T9	101	126	3

Raccordi di completamento con attacco a forchetta nel capitolo:  
End fittings with fork coupling in chapter:  
Empalmes de terminación con toma de horquilla en el capítulo:

**FITTINGS**

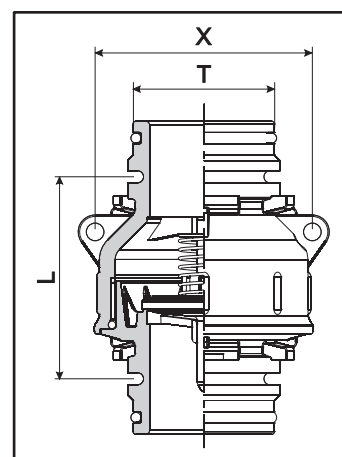

## Valvola di fondo con attacco superiore maschio a forchetta e inferiore filettato femmina

## Foot valve with upper fork male coupling and lower female threaded coupling

## Válvula de fondo con toma superior de horquilla macho y inferior roscada hembra



COD. CODE CÓD.	T	F	h mm	L mm	X mm	 bar
504 2007F	T7	G2	28	93	87	5

Raccordi di completamento con attacco a forchetta nel capitolo:  
End fittings with fork coupling in chapter:  
Empalmes de terminación con toma de horquilla en el capítulo:

**FITTINGS**

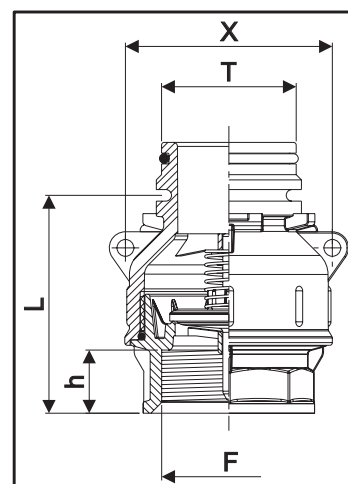

Valvola di fondo con attacchi filettati maschio

Foot valve with male threaded couplings

Válvula de fondo con tomas roscadas macho



COD. CODE CÓD.	F	h	L	X	
		mm	mm	mm	bar
504 2015	G1 1/4	24	105	77	7
504 2016	G1 1/2	24	111	77	
504 2017	G2	27	126	87	5
504 2019	G3	35	153	126	3

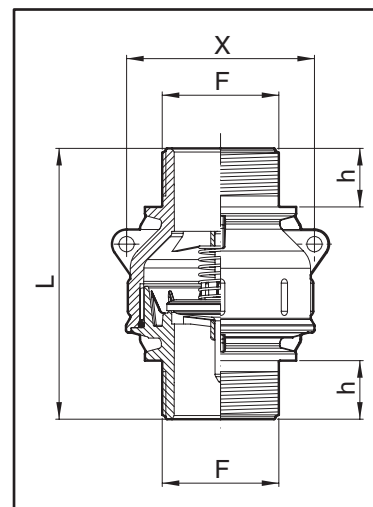

Valvola di fondo con attacchi filettati maschio/femmina

Foot valve with male/female threaded couplings

Válvula de fondo con tomas roscadas macho/hembra



COD. CODE CÓD.	M	F	h	h1	L	X	
			mm	mm	mm	mm	bar
504 2007	G2	G2	27	28	116	87	5



Diagramma perdite di carico  
Pressure drop chart  
Diagrama de perdida de caudal



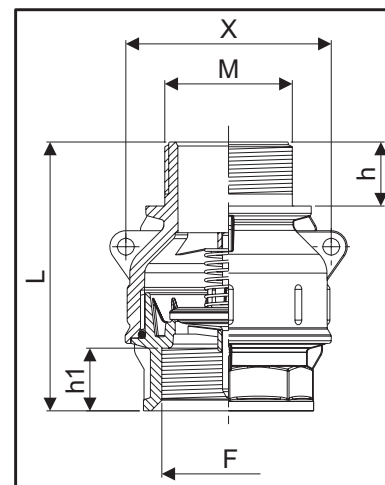
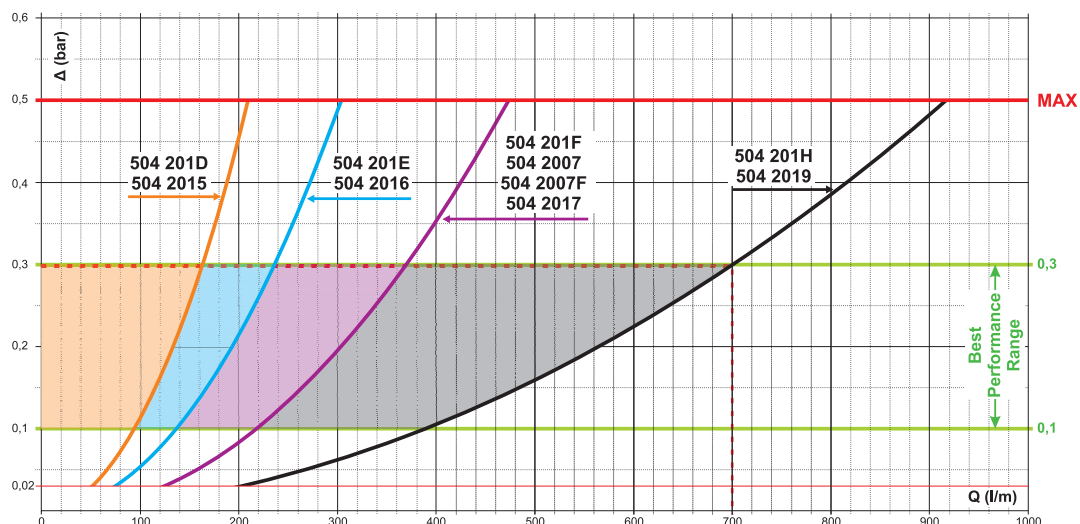

# GETTI LAVA CONTENITORI E LAVA SERBATOI CONTAINER AND TANK RINSING JETS SURTIDORES LAVA CONTENEDORES Y LAVA CISTERNAS

## Getto lava contenitori

- Pulisce i contenitori vuoti (bottiglie - taniche) prima dello smaltimento
- Riduce lo spreco di prodotto
- Con filtro a rete per evitare bloccaggi causati da sporcizia
- Testina rotante azionata dal fluido
- Valvola di sovrappressione (si apre solo premendo il contenitore)



## Container rinsing jet

- Cleans empty containers (bottles-tanks) before disposal
- Reduces product wastage
- With net filter to avoid accidental blockage due to dirty
- Fluid-driven rotating cap
- Pressure relief valve (it opens only when opening vessel)

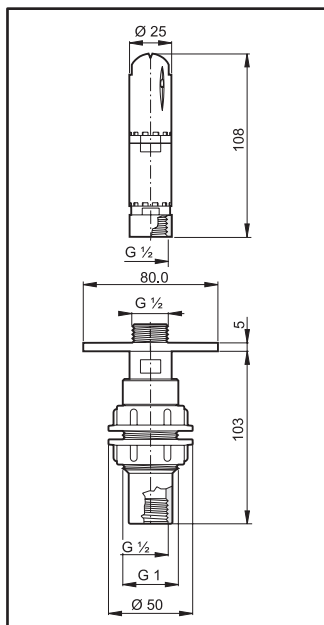

## Get lava contenedores

- Limpia los contenedores vacíos (botellas - tanques)
- Reduce el desperdicio de producto
- Con filtro a malla para evitar el bloqueo causado por suciedad
- Cabezal rotativo accionado por el fluido
- Válvula de sobrepresión (se abre solo presionando el contenedor)

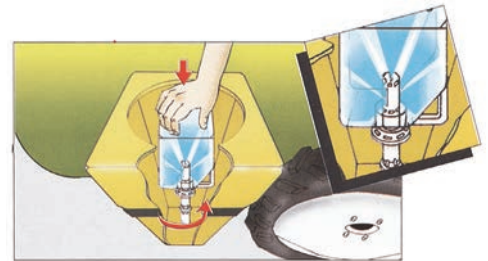

bar	1.5	2	2.5	3	4	5
PSI	22	29	36	44	58	73
l/min	18	20	22	24	28	31
US GPM	5	5	6	6	7	8



## Getto lava serbatoi

- Testina rotante azionata dal fluido
- Lavaggio effettivo a 360° della superficie interna del serbatoio
- Diametro di gittata utile 3 m



## Tank rinsing jet

- Fluid-driven rotating cap
- 360° rinsing of tank interior
- 3 m dia. rinse performance

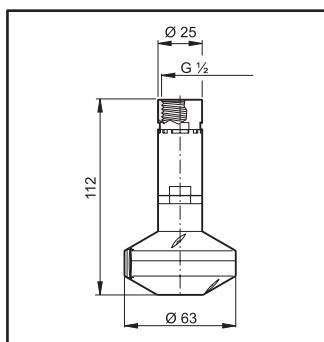

## Surtidor lava cisternas

- Cabezal rotativo accionado por el fluido
- Lavado efectivo a 360° de la superficie interna del depósito
- diametro de lavado efectivo 3 m

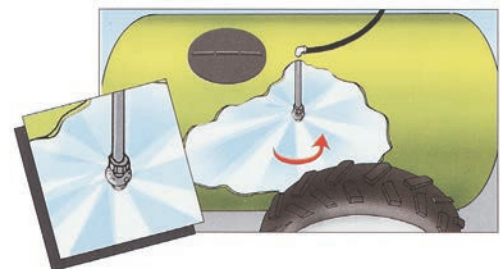

bar	1.5	2	2.5	3	4	5
PSI	22	29	36	44	58	73
l/min	41	47	52	57	67	77
US GPM	11	12	14	15	18	20



## Filtro e porta filtro di ricambio

## Spare filter and filter holder

## Filtro y puerta filtro de repuesto



COD.  
CODE  
CÓD.  
**510 110.060**

COD.  
CODE  
CÓD.  
**510 110.070**



## Idroeiettore antinquinamento con attacco rapido

Può essere utilizzato, in particolare, come efficace agitatore, inserendo l'apposito tappo a corredo.

## Anti-pollution ejector with fast coupling

Particularly useful as an efficient agitator by inserting the special plug.

## Hidrocargador anticontaminante con enlace rápido

Puede utilizarse como eficaz agitador, montando el tapon suministrado consuntamente.

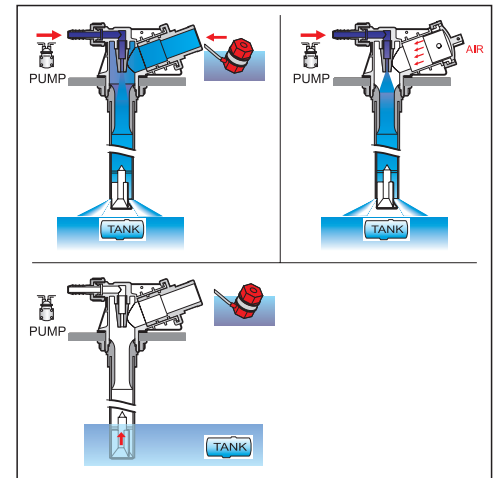
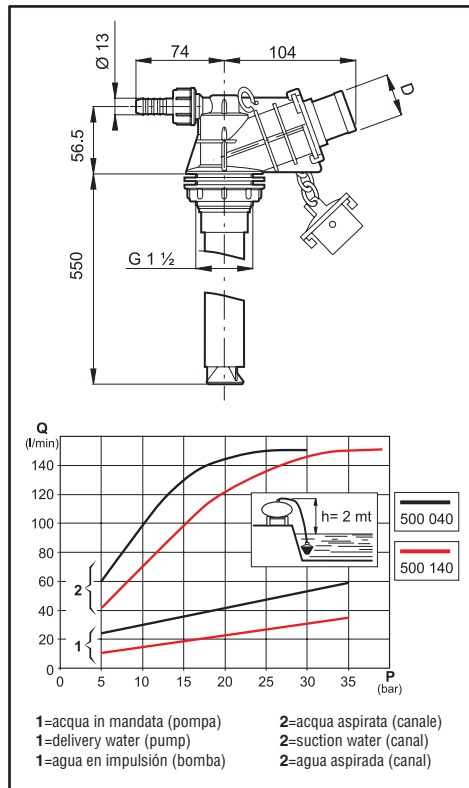

COD. CODE CÓD.	D mm	Ugello Nozzle Boquilla	Pressure	
			bar	PSI
500 030	30	Ø 5 mm	10 ÷ 30	145 ÷ 435
500 035	35			
500 038	38			
500 040	40	Ø 3 mm	15 ÷ 40	218 ÷ 580
500 130	30			
500 135	35			
500 138	38			
500 140	40			

## Idroeiettore antinquinamento con attacco filettato

Può essere utilizzato, in particolare, come efficace agitatore, inserendo l'apposito tappo a corredo.

## Anti-pollution ejector with threaded coupling

Particularly useful as an efficient agitator by inserting the special plug.

## Hidrocargador anticontaminante con enlace roscado

Puede utilizarse como eficaz agitador, montando el tapon suministrado consuntamente.

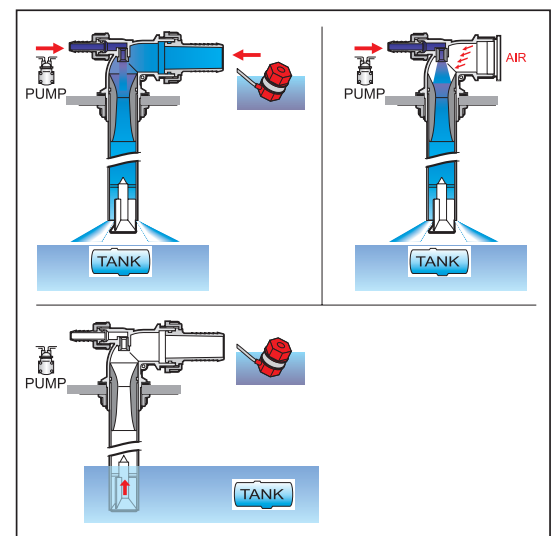
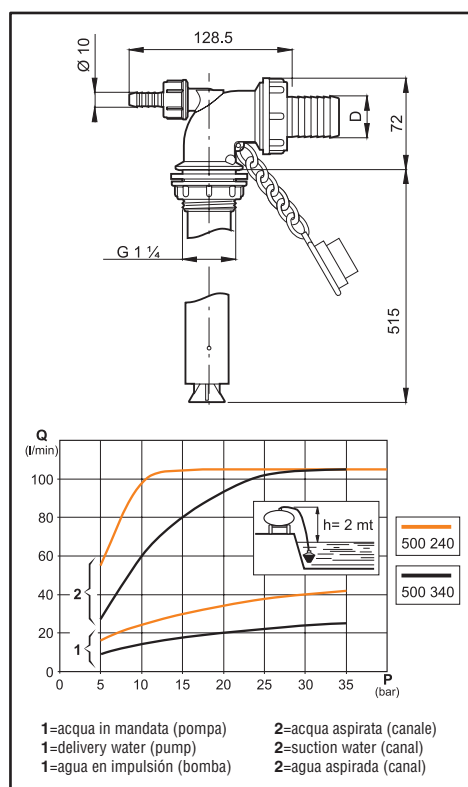

COD. CODE CÓD.	D mm	Ugello Nozzle Boquilla	Pressure	
			bar	PSI
500 232	32	Ø 5 mm	10 ÷ 25	145 ÷ 363
500 240	40			
500 332	32	Ø 3.2 mm	15 ÷ 40	218 ÷ 580
500 340	40			

# IDROEIETTORI EJECTORS HIDROCARGADORES

## Agitatore antisedimento

L'agitatore antisedimento ARAG evita il sedimentamento delle sostanze sul fondo della cisterna, rimescolandole tramite i getti in pressione degli ugelli.

In questo modo le sostanze di trattamento rimangono in sospensione e vengono irrorate correttamente.

- Struttura in PA 6 (Nylon®) rinforzato con fibra vetro
- Guarnizione costampata
- Ugelli interni in Ceramica
- Viti in acciaio inox
- Guarnizioni in EPDM
- Diametro di pulizia 1,5m

## Tank agitator

ARAG tank agitator mixes the substances on tank bottom by means of the pressurized nozzle jets thus avoiding build-up.

In this way, treatment substances remain suspended and are correctly sprayed.

- Body in PA 6 (Nylon) reinforced with fibreglass
- Co-moulded gasket
- Ceramic inner nozzles
- Stainless steel screws
- EPDM seals
- Cleaning diameter 1.5m

## Agitador antisedimento

El agitador antisedimento ARAG evita el sedimentación de las sustancias en el fondo de la cisterna, mezclándolas a través de los chorros en presión de las boquillas. De esta manera las sustancias de tratamiento permanecen en suspensión y se pulverizan correctamente.

- Estructura de PA 6 (Nylon) reforzado con fibra de vidrio
- Junta co-moldeada
- Boquillas internas de Cerámica
- Tornillos de acero inox
- Juntas de EPDM
- Diametro de limpieza 1,5m



**T3**  
fork  
coupling

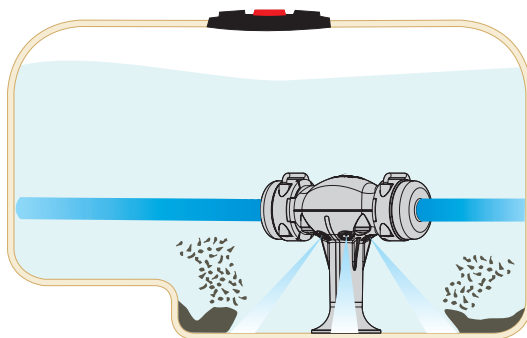

COD. CODE CÓD.	T	Ugello Nozzle Boquilla Ø (mm)	bar
502 0715	T3	1.5	5÷15
502 072		2	

Raccordi di completamento con attacco a forchetta nel capitolo:  
End fittings with fork coupling in chapter:  
Empalmes de terminación con toma de horquilla en el capítulo:

### FITTINGS

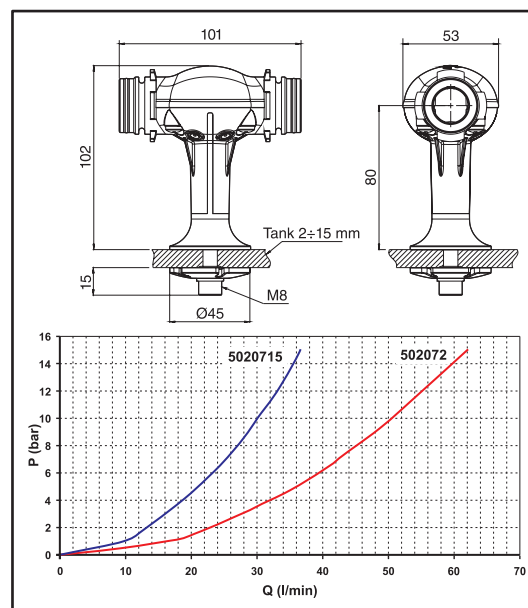

## Eiettore con filtro per riempimento cisterna con attacco filettato

- Filtro in acciaio inox
- Corpo in polipropilene
- Attacco filettato G 1 ¼

## Tank filling ejector with filter and threaded coupling

- Stainless steel filter
- Polypropylene body
- 1 ¼" BSP threaded coupling

## Hidrocargador con filtro con conexión roscada

- Filtro de acero inox
- Cuerpo de polipropileno
- Acoplamiento roscado G 1 ¼



COD. CODE CÓD.	F	bar	PSI
500 415	BSP G 1 1/4	10 ÷ 40	145 ÷ 580

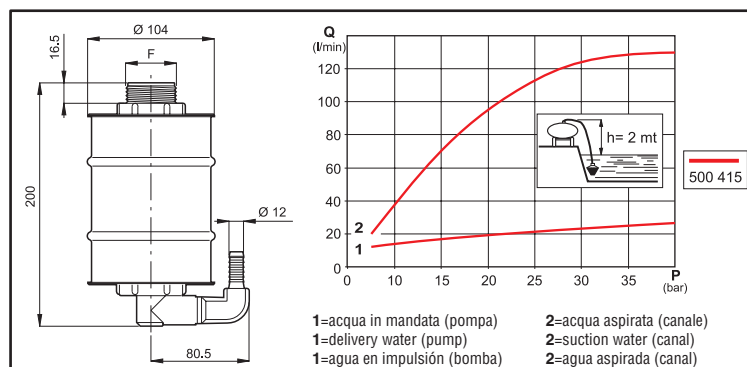
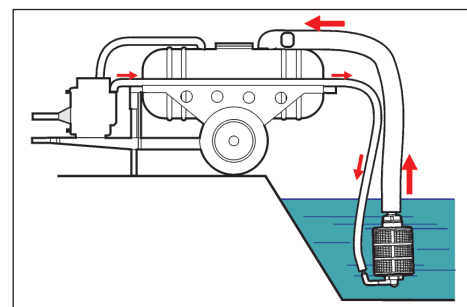

Miscelatore idraulico per polveri

Hydraulic powder mixer

Mezclador hidráulico para polvos

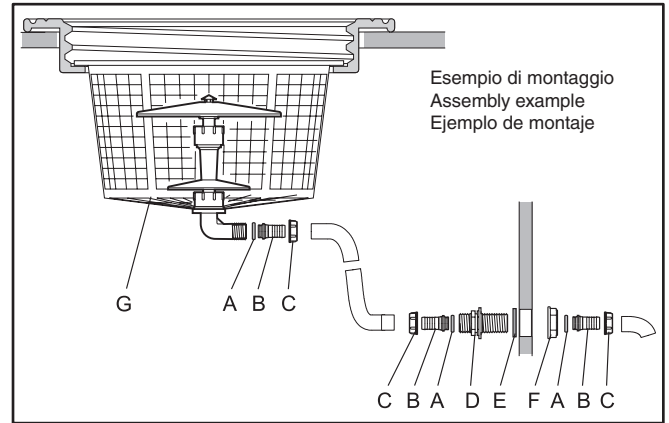
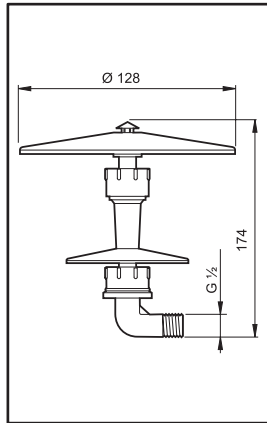

COD.  
CODE  
CÓD.  
**502 001**

POS. / POS. / POS.	A	B	C	D	E	F	G
COD. CODE CÓD.	G11060	106 211 106 213	200 2020	250 2021	G40002	205 2020	300 120 - 300 122 300 124 - 300 126 300 128 - 300 130 300 132 - 300 134 300 136

Miscelatore idraulico per polveri in acciaio Inox

Stainless steel hydraulic powder mixer

Mezclador hidráulico para polvos de acero inox

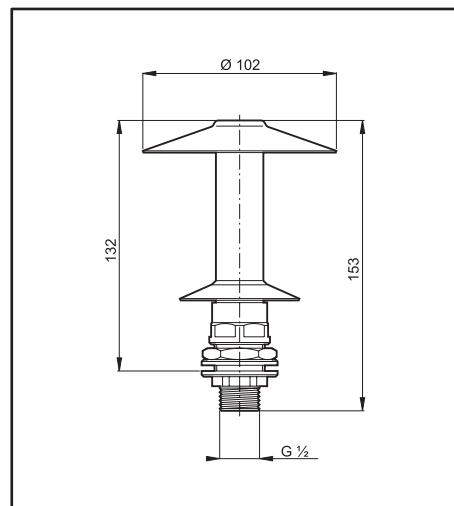
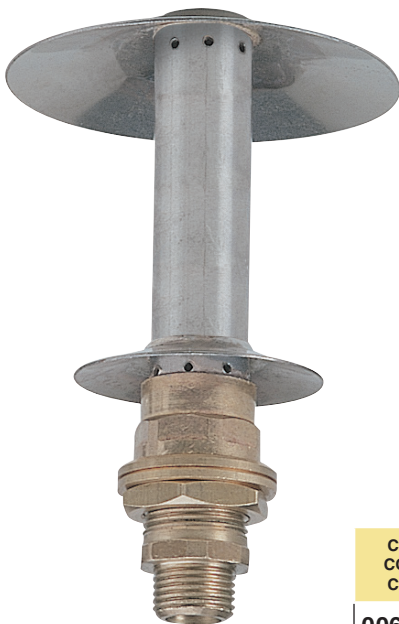

COD.  
CODE  
CÓD.  
**006 830**

# AGITATORI IDRAULICI HYDRAULIC STIRRERS AGITADORES HIDRAULICOS

## Agitatore idraulico "SUPERMIX"

Raggruppa in un solo corpo tre circuiti:

- A** Pressione
- B** Ritorno
- C** Iniezione prodotto, pompa addizionale o miscela con aria

### Circuito A: PRESSIONE

Usando la pressione di lavoro, la potenza di miscelazione superiore ai sistemi tradizionali consentendo un passaggio da 300 a 1300 l/min secondo la pompa e l'ugello utilizzati. Il grafico "A2" evidenzia i consumi, il grafico "A1" i corrispondenti rendimenti con ugelli diametro 1,5 - 2 - 2,5 - 3 mm.

### Circuito B: RITORNO

Questo circuito sfrutta il ritorno della pompa durante le operazioni di fine corsa, manovra, riempimento serbatoio, quando tutta la mandata della pompa passa attraverso il circuito. Consigliato nei trattamenti a bassa pressione, medio e basso volume, sistemi pneumatici, diserbo. Il grafico "B2" evidenzia la pressione residua nel circuito a diverse portate, il grafico "B1" i corrispondenti rendimenti senza ugello o con ugelli diametro 13 - 15 - 17 mm.

## "SUPERMIX" hydraulic agitator

The SUPERMIX body contains three circuits:

- A** Pressure
- B** Return
- C** Product injection, additional pump or air mixing

### Circuit A: PRESSURE

By using the working pressure, the mixing power of SUPERMIX is greater than the performance of traditional systems, ensuring a flow rate of 300 to 1300 l/min. depending on the pump and nozzle used. Graph "A2" illustrates consumption, while graph "A1" shows the corresponding performance values using nozzles with diameter 1.5 - 2 - 2.5 - 3 mm.

### Circuit B: RETURN

This circuit utilises the pump return flow during limit, control and tank filling operations, when all the pump delivery fluid passes through the circuit. Recommended for low-pressure treatments, average and low volumes, pneumatic systems and spraying. Graph "B2" illustrates the residual pressure in the circuit at various flow rates, while graph "B1" shows the corresponding performance values without a nozzle and using nozzles with diameter 13 - 15 - 17 mm.

## Agitador hidráulico "SUPERMIX"

Agrupar en un sólo cuerpo tres circuitos:

- A** Presión
- B** Retorno
- C** Inyección producto, bomba adicional o mezcla con aire

### Circuito A: PRESION

Con este sistema, que usa la presión de trabajo, se obtiene una potencia de mezcla es muy superior a los sistemas tradicionales, con un paso de 300 a 1300 l/min, en función de la bomba y de la boquilla utilizada. El gráfico "A2" muestra los consumos, y el gráfico "A1" los correspondientes rendimientos con boquillas de diámetro 1.5 - 2 - 2.5 - 3 mm.

### Circuito B: RETORNO

Este circuito aprovecha el retorno de la bomba durante las operaciones de fin de carrera, maniobra, llenado de la cisterna, cuando todo el caudal de la bomba pasa a través del circuito. Se aconseja para tratamientos a baja presión, de mediano y bajo volumen, sistemas neumáticos y aplicaciones de herbicidas. El gráfico "B2" muestra la presión residual en el circuito con diferentes caudales, y el gráfico "B1" muestra los rendimientos sin boquilla o con boquillas de diámetro 13 - 15 - 17 mm.

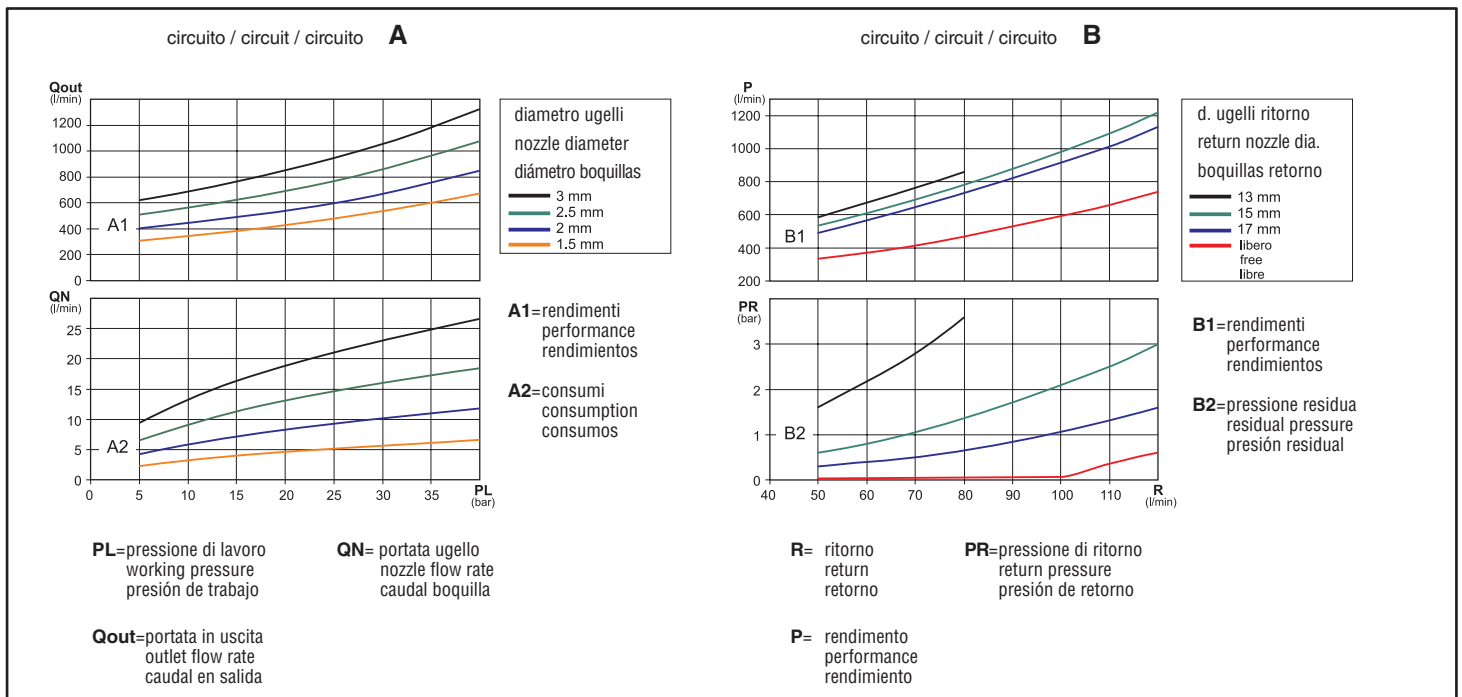
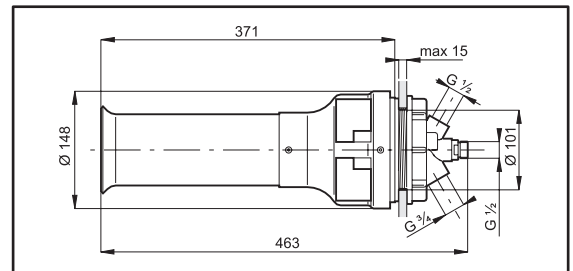



# AGITATORI IDRAULICI HYDRAULIC STIRRERS AGITADORES HIDRAULICOS

- Adattabile alle diverse conformazioni della cisterna
- Doppio circuito Venturi per incrementare il rendimento e ridurre il consumo di acqua
- Attacco filettato G 1/2 per una semplice installazione sulla cisterna
- Idoneo al funzionamento con basse pressioni (ugelli Ø 5-7-9 mm) o alte pressioni (ugelli Ø 2-3 mm)
- Corpo in Polipropilene

- Can be adapted to various tank shapes
- Double Venturi circuit to increase efficiency and reduce water consumption
- Threaded G 1/2 connector for simple installation on tank
- Suitable for low pressure (nozzles Ø 5-7-9- mm) or high pressure (nozzles Ø 2-3 mm) operation
- Polypropylene body

- Adaptable a las diferentes conformaciones de la cisterna
- Doble circuito Venturi para aumentar el rendimiento y reducir el consumo de agua
- Unión roscada G 1/2 para una fácil instalación en la cisterna
- Idóneo para funcionar con bajas presiones (boquillas Ø 5-7-9 mm) o altas presiones (boquillas Ø 2-3 mm).
- Cuerpo de polipropileno

## Agitatore idraulico orientabile ispezionabile Checkable swivel hydraulic agitator Agitador hidráulico orientable inspeccionable

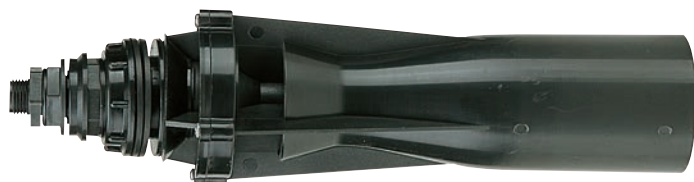

COD. / CODE / CÓD.	Ugello / Nozzle / Boquilla	
502 062	2 mm	CERAMIC
502 063	3 mm	CERAMIC
502 065	5 mm	CERAMIC
502 067	7 mm	INOX / S.S.
502 069	9 mm	POLYPROP.

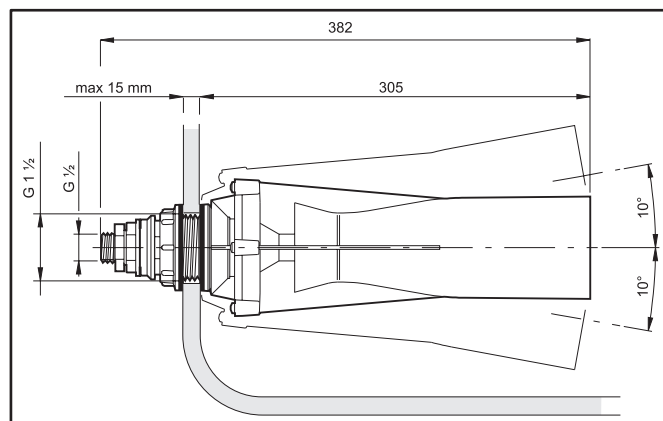

## Agitatore idraulico ispezionabile Checkable hydraulic agitator Agitador hidráulico inspeccionable

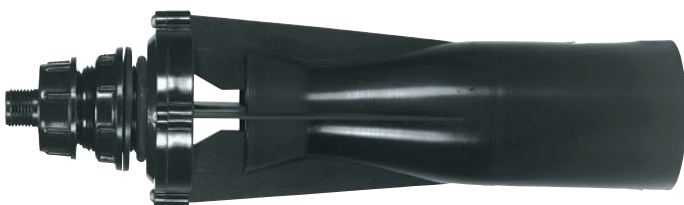

COD. / CODE / CÓD.	Ugello / Nozzle / Boquilla	
502 162	2 mm	CERAMIC
502 163	3 mm	CERAMIC
502 165	5 mm	CERAMIC
502 167	7 mm	INOX / S.S.
502 169	9 mm	POLYPROP.

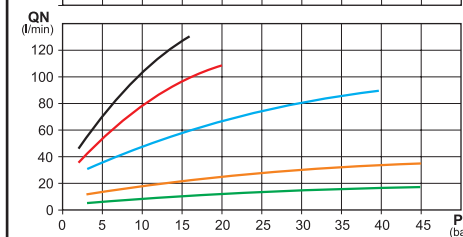
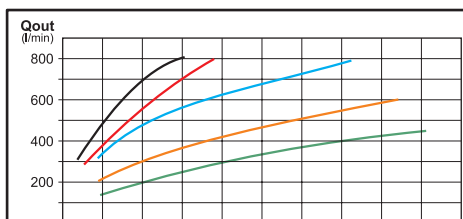
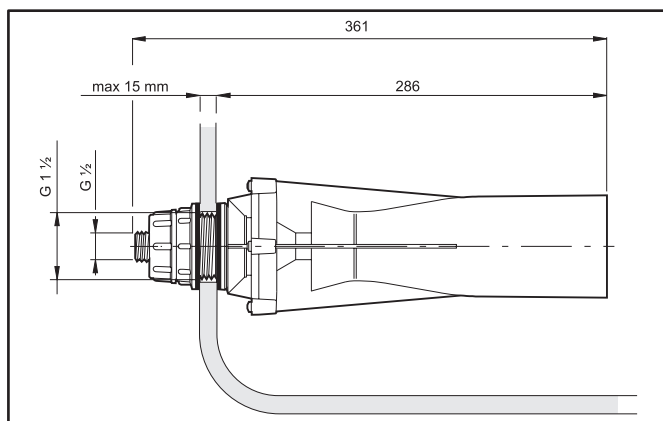

diametro ugelli  
nozzle diameter  
diámetro boquillas

- 2 mm
- 3 mm
- 5 mm
- 7 mm
- 9 mm

PL= pressione di lavoro  
working pressure  
presión de trabajo

QN= portata ugello  
nozzle flow rate  
caudal boquilla

Qout= portata in uscita  
outlet flow rate  
caudal en salida

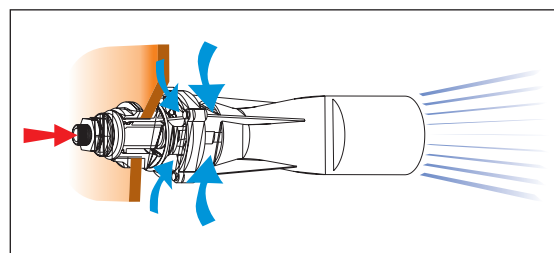

# AGITATORI IDRAULICI HYDRAULIC STIRRERS AGITADORES HIDRAULICOS

## Agitatore idraulico ispezionabile



## Hydraulic agitator with inspection hole

COD. CODE CÓD.	Ugello Nozzle Boquilla	
502 20312	1.2 mm	CERAMIC
502 20315	1.5 mm	CERAMIC
502 2032	2.0 mm	CERAMIC
502 2033	3.0 mm	CERAMIC
502 2035	5.0 mm	CERAMIC

## Agitador hidráulico inspeccionable

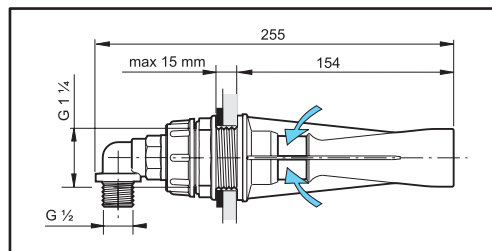

COD. CODE CÓD.	Ugello Nozzle Boquilla	
502 20412	1.2 mm	CERAMIC
502 20415	1.5 mm	CERAMIC
502 2042	2.0 mm	CERAMIC
502 2043	3.0 mm	CERAMIC
502 2045	5.0 mm	CERAMIC

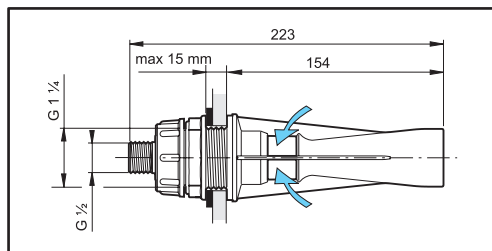

## Agitatore idraulico antischiuma

## Anti-foam hydraulic agitator

## Anti-espuma agitador hidráulico



COD. CODE CÓD.	Ugello Nozzle Boquilla	
502 21312	1.2 mm	CERAMIC
502 21315	1.5 mm	CERAMIC
502 2132	2.0 mm	CERAMIC
502 2133	3.0 mm	CERAMIC
502 2135	5.0 mm	CERAMIC

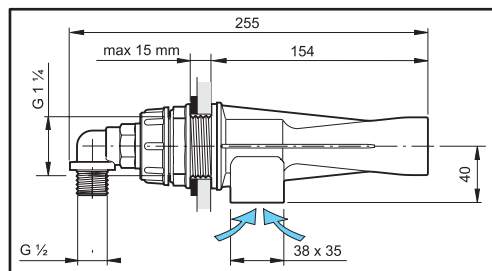

COD. CODE CÓD.	Ugello Nozzle Boquilla	
502 21412	1.2 mm	CERAMIC
502 21415	1.5 mm	CERAMIC
502 2142	2.0 mm	CERAMIC
502 2143	3.0 mm	CERAMIC
502 2145	5.0 mm	CERAMIC

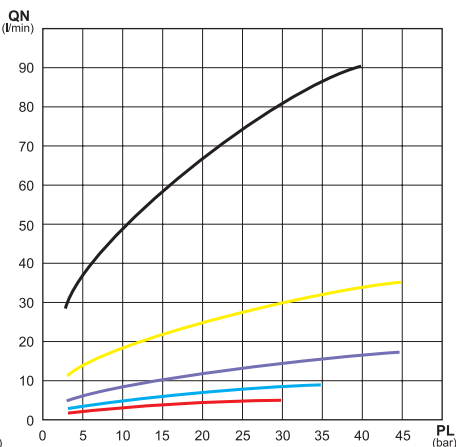
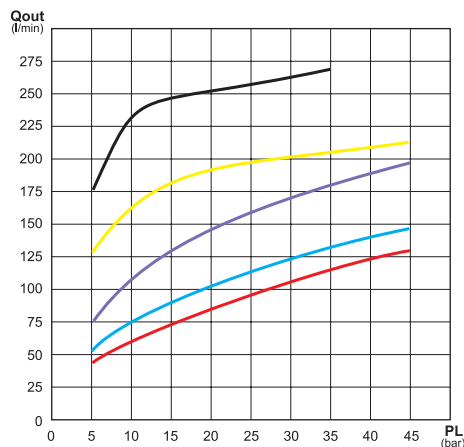
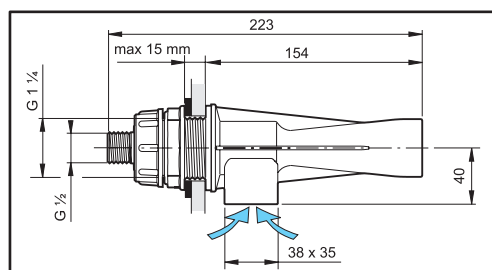

diametro ugelli  
nozzle diameter  
diámetro boquillas

— 5.0 mm  
— 3.0 mm  
— 2.0 mm  
— 1.5 mm  
— 1.2 mm

PL= pressione di lavoro  
working pressure  
presión de trabajo

QN= portata ugello  
nozzle flow rate  
caudal boquilla

Qout= portata in uscita  
outlet flow rate  
caudal en salida

# AGITATORI IDRAULICI HYDRAULIC STIRRERS AGITADORES HIDRAULICOS

Agitatore idraulico ispezionabile con raccordo a cavallotto.

Hydraulic agitator with opening for inspection and clamp fitting.

Agitador hidráulico inspeccionable con racor con abrazadera.

**NEW**



*COD. *CODE *CÓD.	Q.TÀ DA ORDINARE Q.TY TO BE ORDERED CANTIDAD DE PEDIR
V2B25F	1

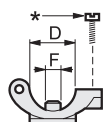

COD. CODE CÓD.	D	F (mm)
400 8201	20 mm	10
400 840	1/2"	10
400 85A0	25 mm	10
400 850	3/4"	10
400 860	1"	10

COD. CODE CÓD.	Ugello Nozzle Boquilla	
502 20412	1.2 mm	CERAMIC
502 20415	1.5 mm	CERAMIC
502 2042	2.0 mm	CERAMIC
502 2043	3.0 mm	CERAMIC
502 2045	5.0 mm	CERAMIC

COME ORDINARE  
HOW TO ORDER  
COMO PEDIR

Es. vite V2B25F + raccordo a cavallotto 400 850 + agitatore idraulico 502 20415  
Ex. screw V2B25F + clamp fitting 400 850 + hydraulic agitator 502 20415  
Ej. tornillo V2B25F + racor con abrazadera 400 850 + agitador hidráulico 502 20415

## Agitatore idraulico

Ugello in acciaio INOX con foro Ø 1.2 mm.

## Hydraulic agitator

STAINLESS steel nozzle with Ø 1,2 mm hole.

## Agitador hidráulico

Boquilla de acero inoxidable con orificio de 1.2 mm de diámetro.



COD.  
CODE  
CÓD.  
**502 010**

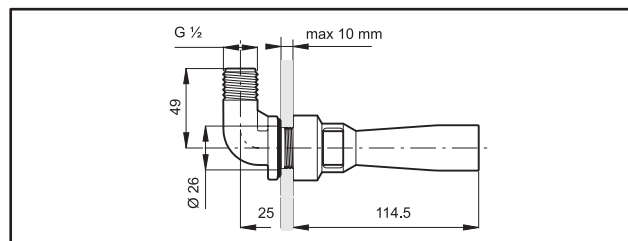

COD.  
CODE  
CÓD.  
**502 020**

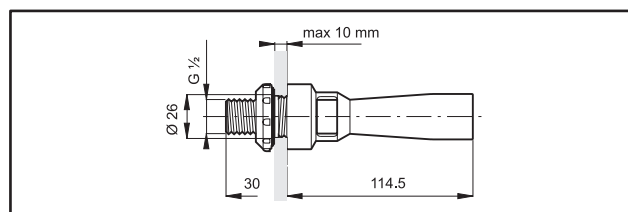

## Agitatore idraulico

In ottone completo di filtro inox.  
Ugello in ceramica con foro Ø 1.5 mm.

## Hydraulic agitator

In brass with stainless steel filter.  
Ceramic nozzle hole Ø 1.5 mm.

## Agitador hidráulico

De latón con filtro inox. Boquilla de cerámica con orificio de 1.5 mm de diámetro.



COD.  
CODE  
CÓD.  
**004 500**

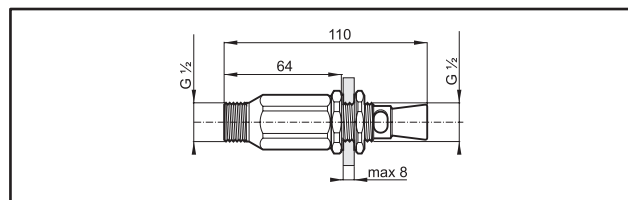

## Agitatore a canna

Completo di raccordo curvo Ø 10 mm.

## Tube agitator

Including bent fitting Ø 10 mm.

## Agitador de tubo

Con empalme curvo Ø 10 mm.



COD.  
CODE  
CÓD.  
**004 510**

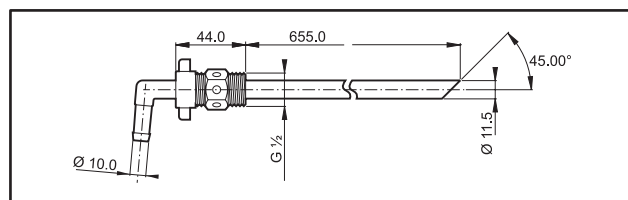

# VALVOLE DI SCARICO DRAIN VALVES VALVULAS DE DESCARGA

Valvola di scarico antinquinante G 2

2" BSP anti-pollution drain valve

Válvula de descarga anti contaminación G 2



COD.  
CODE  
CÓD.

452 107

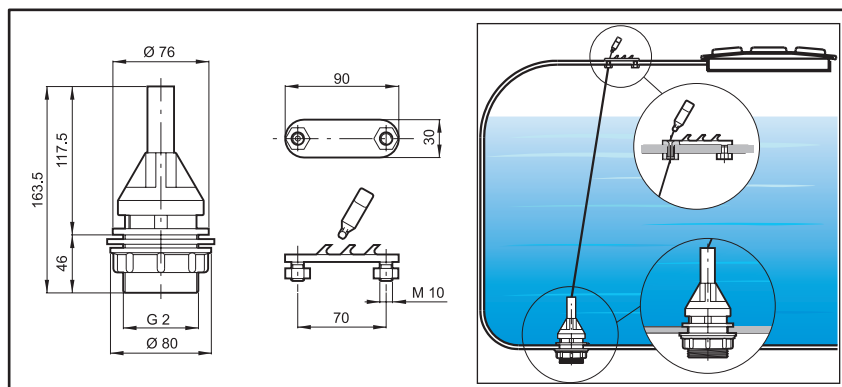

Valvola di scarico antinquinante G 1 ¼

1 ¼" BSP anti-pollution drain valve

Válvula de descarga anti contaminación G 1 ¼



COD. CODE CÓD.	tipo type tipo
452 005	Standard
452 015	con portagomma Ø 30 mm with hose fitting Ø 30 mm con portamangueras Ø 30 mm

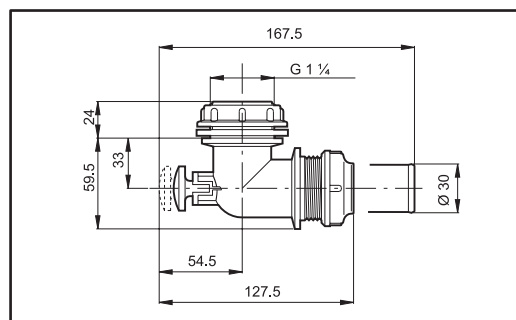

Bocchettone di scarico

Drain outlet

Racor de desagüe



COD. CODE CÓD.	F (BSP)	
220 029	G 1/2	25
220 039	G 3/4	25
220 049	G 1	25
220 059	G 1 1/4	25
220 069	G 1 1/2	25
220 079	G 2	10
220 089	G 2 1/2	10

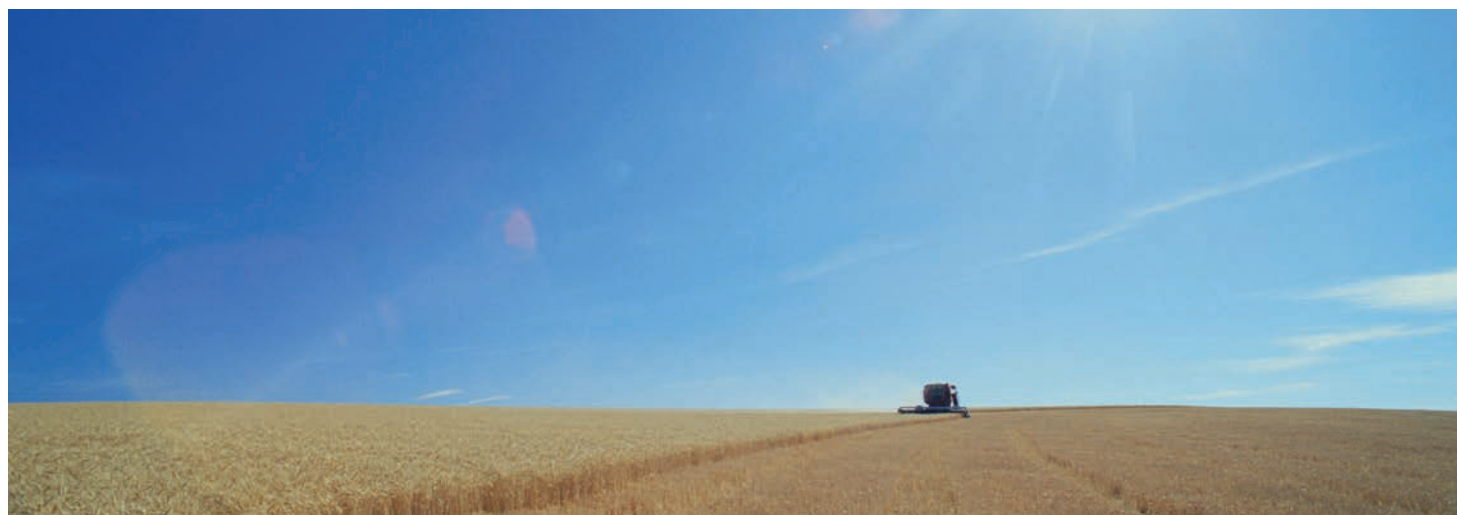
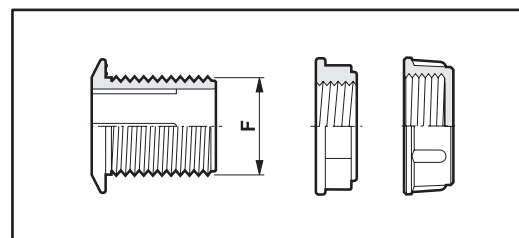



Indicatore livello serbatoio

Tank level indicator

Indicador de nivel para cisterna

COD.  
CODE  
CÓD.  
**508 010**



Kit indicatore livello serbatoio completo di tubo

Tank level indicator kit including tube

Kit indicador de nivel cisterna con tubo

COD.  
CODE  
CÓD.  
**509 219**

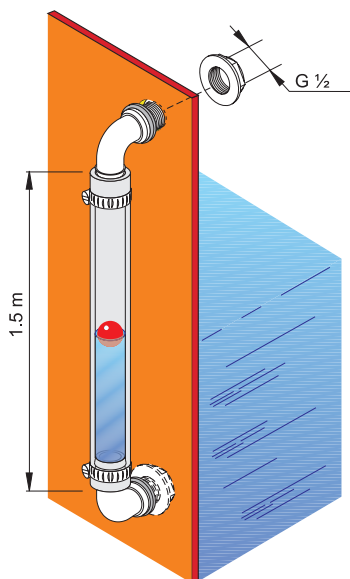

Indicatore livello serbatoio

- Quadrante circolare
- Trasmissione meccanica in ottone e acciaio
- Scala graduata non compresa

Tank level indicator

- Circular dial
- Mechanical transmission in brass and steel
- Graduated gauge not included

Indicador nivel depósito

- Cuadrante circular
- Transmisión mecánica de latón y acero
- Escala graduada no incluida

COD.  
CODE  
CÓD.  
**508 015**



# REGOLATORI MODULARI MODULAR REGULATORS REGULADORES MODULARES

## Regolatori modulari per macchine a basso volume

La modularità del sistema offre soluzioni per le più disparate configurazioni di macchina, garantendo nel contempo altissima precisione d'esercizio. La ghiera graduata consente di preimpostare agevolmente i parametri di lavoro per ogni tipo di trattamento.

## Modular regulators for low volume sprayers

The modularity of the system offers solutions for any kind of machine's configuration, granting at the same time very high precision of exercise. The graduated nut allows the easy setting up of working parameters for every kind of treatment.

## Reguladores modulares para máquinas de bajo volumen

La modularidad del sistema ofrece soluciones para las más disparatadas configuraciones de máquina, garantizando en el mismo tiempo una muy altísima precisión en el ejercicio. La tuerca graduada permite imposter los parámetros de trabajo para cada tipo de tratamiento.

Raccordo maschio portamanometro G1/4  
Male fitting for pressure gauge G1/4  
Racor macho con portamanómetro G1/4

COD. / CODE / CÓD.

219 135

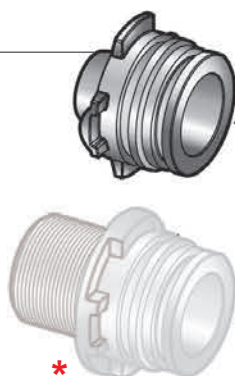

O'ring

COD  
CODE  
CÓD.

G11058

O'ring

COD  
CODE  
CÓD.

G11056

Corpo con doppio attacco a forchetta  
Body with double fork coupling  
Cuerpo con acople doble a horquilla

COD. / CODE / CÓD.

440 D31

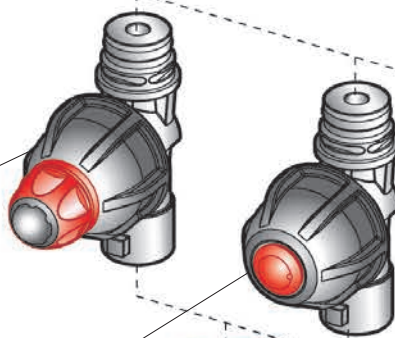

Uniget con antigoccia, rubinetto e attacco rapido  
Nozzle holder with check valve, stopcock and quick fitting  
Uniget con antigota, grifo y acople rapido

COD. / CODE / CÓD.

402 315C



10

Uniget con antigoccia e attacco rapido  
Nozzle holder with check valve and quick fitting  
Uniget con antigota y acople rapido

COD. / CODE / CÓD.

402 315



10

Testina attacco rapido  
Quick fitting cap  
Cabezal de acople rapido

COD. / CODE / CÓD.

402 90403

Portagomma per tubo Ø 8 mm  
Hose fitting for hose Ø 8 mm  
Portamanguera para tubo Ø 8mm

COD. / CODE / CÓD.

105 108R

Portagomma  
Hose fitting  
Portamanguera

COD. / CODE / CÓD.

105 108A

Ø 8 mm

105 110A

Ø 10 mm

Uniget con innesto rapido per tubo e antigoccia  
Uniget with quick coupling for hose and check valve  
Uniget con acople rapido para tubo y antigota

COD. / CODE / CÓD.

402 415

Ø 6 mm

402 425

Ø 8 mm

Uniget con innesto rapido per tubo Ø 8 mm, antigoccia e testina filettata G 3/8  
Uniget with quick coupling for hose Ø 8 mm, check valve and threaded cap 3/8"  
Uniget con acople rapido para tubo Ø 8mm, antigota y boquilla rosca G 3/8

COD. / CODE / CÓD.

402 625

10

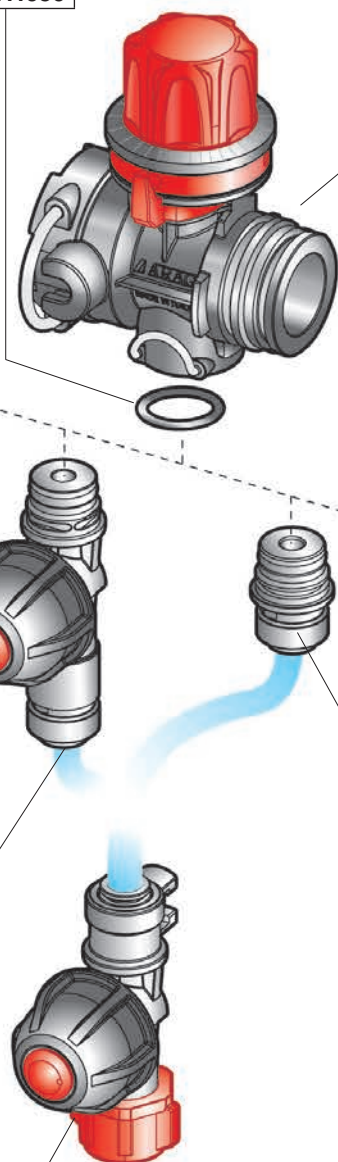

# REGOLATORI MODULARI MODULAR REGULATORS REGULADORES MODULARES

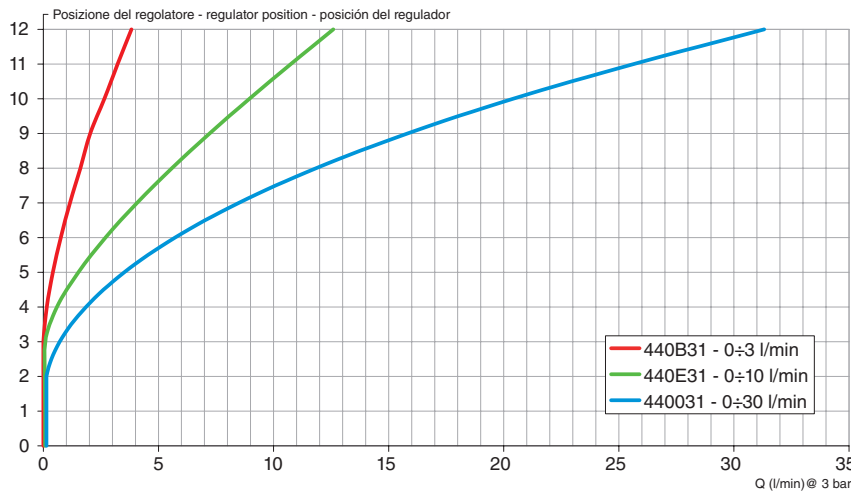

**Corpo con regolazione / Body with regulation / Cuerpo con regulacion**

<b>COD. / CODE / CÓD.</b> <b>440 B31</b> 0÷3 l/min	<b>COD. / CODE / CÓD.</b> <b>440 E31</b> 0÷10 l/min	<b>COD. / CODE / CÓD.</b> <b>440 O31</b> 0÷30 l/min
--	---	---

**Corpo con singolo att. a forchetta**  
Body with single fork coupling  
cuerpo acople simple a horquilla

**COD. / CODE / CÓD.**  
**440 C31**

**Raccordo femmina portamanometro G1/4**  
Female fitting for pressure gauge G1/4  
Racor hembra con portamanómetro G1/4

**COD. / CODE / CÓD.**  
**219 035**

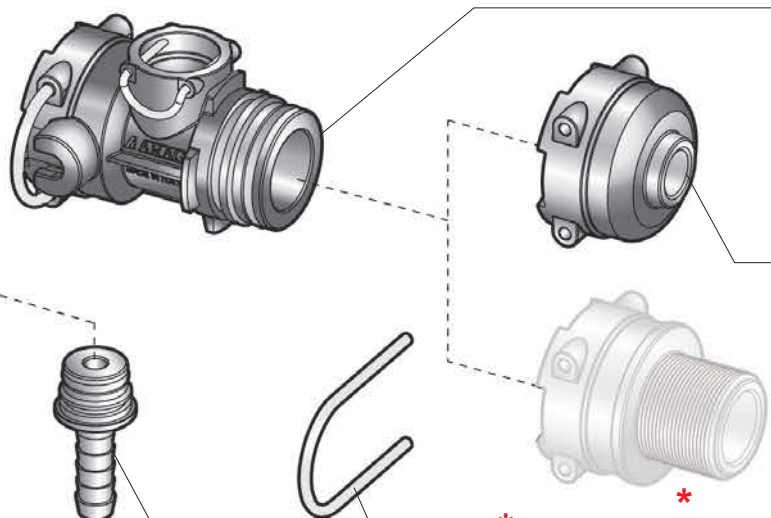

**\* T3** Raccordi di completamento con attacco a forchetta nel capitolo:  
End fittings with fork coupling in chapter:  
Empalmes de terminación con toma de horquilla en el capítulo:

**FITTINGS**

**Forchetta**  
Fork  
Horquilla

**COD. / CODE / CÓD.**  
**010 003**

**Attacco rapido per tubo**  
Quick fitting for hose  
Acople rapido por tubo

COD. / CODE / CÓD.	Ø
109 11C08	8 mm
109 11C00	1/4"
109 11C01	3/8"

**Portagomma**  
Hose fitting  
Portamanguera

COD. / CODE / CÓD.	Ø
109 1108	8 mm
109 1110A	10 mm
109 1113A	13 mm





**POMPE 12V**  
**12V PUMPS**  
**BOMBAS 12V**



Le pompe a membrana NORTHSTAR e REMCO sono adatte ai più svariati utilizzi, su macchine agricole, camper, roulotte, barche e qualunque altro mezzo mobile o installazione fissa dove si rende necessario lavorare a 12Vdc e disporre di una buona portata in dimensioni ridotte.

NORTHSTAR and REMCO diaphragm pumps are suitable for various applications, on farming machinery, caravans, motor homes, boats and any other moveable means of fixed installation where it is necessary to work at 12Vdc and have a good range in compact-size.

Las bombas de membrana NORTHSTAR y REMCO son aptas para usos variados: en máquinas agrícolas, auto caravanas, casas rodantes, barcos y en cualquier otro medio de transporte o instalación fija donde sea necesario trabajar a 12Vdc y contar con un gran caudal en dimensiones reducidas.

- 5 membrane
- Attacco rapido 5D
- Peso 2,7 kg
- Completo di:  
raccordo 5D / 1/2" NPT (1 pz.)  
raccordo 5D / portagomma Ø 13 mm (1 pz.)

- 5 diaphragms
- 5D quick fittings
- Weight 2,7 kg
- Provided with:  
5D / 1/2" NPT fitting (1 pcs)  
5D / hose tail Ø 13 mm fitting (1 pcs)

- 5 membranas
- acople rápido 5D
- Peso 2,7 kg
- Completo de:  
n° 1 racor 5D / 1/2" NPT (1 pc)  
n° 1 racor 5D / porta manguera Ø 13 mm (1 pc)

**NORTHSTAR**  
Proven Performance  
**NSQ SERIES™ 3062**  
**long life**



COD. CODE CÓD.			l/min	US GPM	Ø IN/OUT	Tipo Type Tipo	
	bar	PSI					
<b>F2326 81042</b>	4	60	11,40	3	5D	DEMAND	12Vdc 10 A

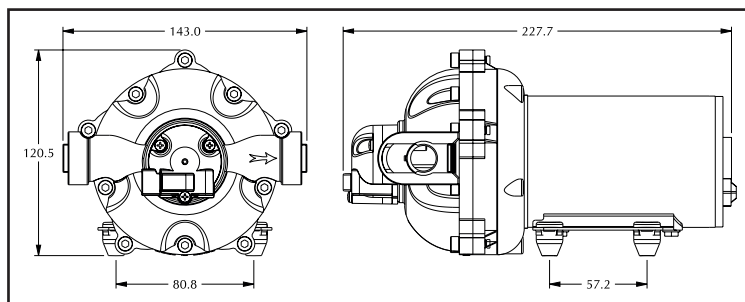

- Valvole in Viton®
- Membrane in SANTOPRENE®
- Raccordi di accoppiamento con portagomma (serie 2200) o attacco rapido 3D e 5D (serie 3300 e 5500)

- Viton® valves
- SANTOPRENE® diaphragms
- Couplings with hose tail (2200 series) or 3D and 5D quick fittings (3300 and 5500 series)

- Válvulas de Viton®
- Membranas de SANTOPRENE®
- Empalmes con acoples con porta manguera (serie 2200) o acople rápido 3D y 5D (serie 3300 y 5500)

**REMCO**  
**ProFio**  
Professional Grade **5500**

- 5 membrane
- Attacco rapido 5D
- Peso 3,6 kg

- 5 diaphragms
- 5D quick fitting
- Weight 3,6 kg

- 5 membranas
- Acople rápido 5D
- Peso 3,6 kg



COD. CODE CÓD.			l/min	US GPM	Ø IN/OUT	Tipo Type Tipo	
	bar	PSI					
<b>F2155 171C1</b>	4	60	19	5	5D	DEMAND	12Vdc 18A
<b>F2155 172C1</b>	4	60	19	5	5D	BY PASS	12Vdc 18A

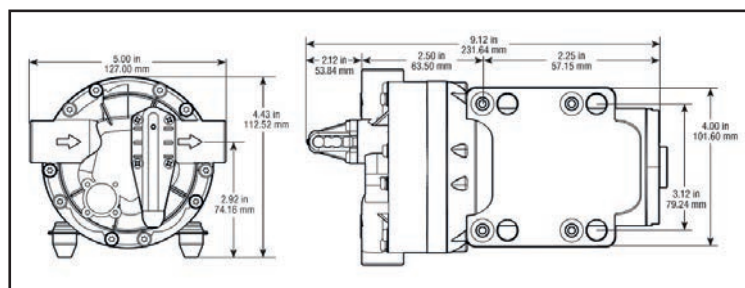





- 3 membrane
- Attacco rapido 3D
- Peso 2,7 kg

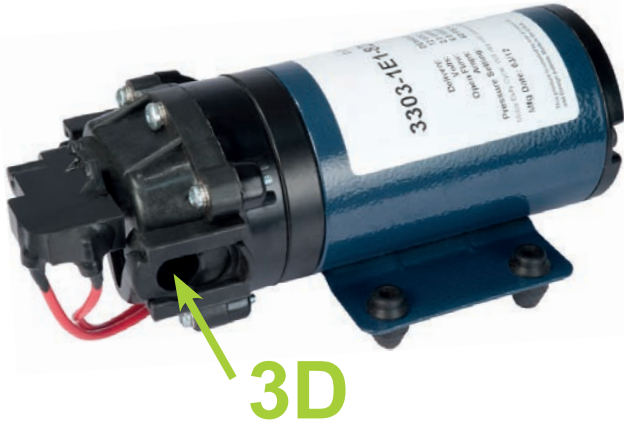

- 3 diaphragms
- 3D quick fitting
- Weight 2.7 kg

- 3 membranas
- Acople rápido 3D
- Peso 2,7 kg

COD. CODE CÓD.			l/min	US GPM	Ø IN/OUT	Tipo Type Tipo	
	bar	PSI					
<b>F2133 031E1</b>	4	60	7,20	2	3D	DEMAND	12Vdc 7,5A
<b>F2133 032E1</b>	4	60	7,20	2	3D	BY PASS	12Vdc 7,5A

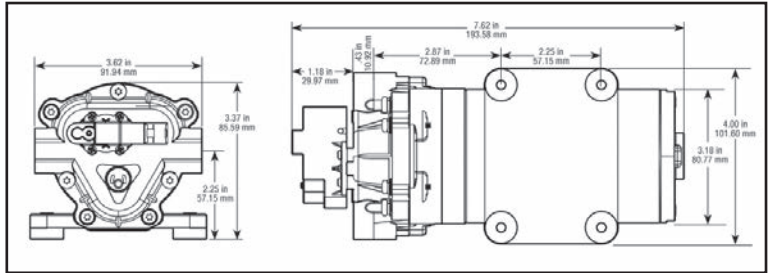

- 2 membrane
- Attacco portagomma 3/8"
- Peso 0,6 kg



- 2 diaphragms
- 3/8" hose tail
- Weight 0.6 kg

- 2 membranas
- Acoples con porta manguera 3/8"
- Peso 0,6 kg

COD. CODE CÓD.			l/min	US GPM	Ø IN/OUT	Tipo Type Tipo	
	bar	PSI					
<b>F2122 401B1</b>	2,8	40	3,80	1	3/8" hose barb	DEMAND	12Vdc 2,9A

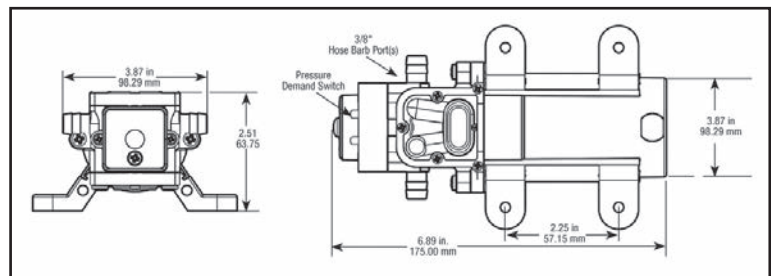

Raccordi ad attacco rapido in Nylon® per pompe

Nylon® quick fitting hosetails for pumps

Racores portamanguera acople rapido de Nylon® para bombas



Serie pompe Pumps series Bombas serie	Tipo Type Tipo	COD. CODE CÓD.	A	COD. CODE CÓD.	A	COD. CODE CÓD.	M	COD. CODE CÓD.	Ø
			mm		mm				
3300	3D	<b>F173DFA38</b>	10	<b>F173DFE38</b>	10	<b>9623202</b>	1/2" M	<b>9623408</b>	Attacco rapido per tubo RILSAN Ø8 Quick coupling for Ø8 RILSAN tube Acople rápido para tubo RILSAN Ø8
		<b>F173DFA12</b>	13	<b>F173DFE12</b>	13				
5500	5D	<b>F175DFA38</b>	10	<b>F175DFE38</b>	10	<b>9625202</b>	1/2" M	<b>9625408</b>	Attacco rapido per tubo RILSAN Ø8 Quick coupling for Ø8 RILSAN tube Acople rápido para tubo RILSAN Ø8
		<b>F175DFA12</b>	13	<b>F175DFE12</b>	13				

# FILTRI E VALVOLE DI REGOLAZIONE PER POMPE A 12V

## FILTERS AND REGULATING VALVES FOR 12V PUMPS

### FILTROS Y VALVULAS DE REGULACION PARA BOMBAS A 12V

#### Minifiltri di aspirazione

- Corpo in Polipropilene
- Guarnizioni in EPDM
- Cartuccia in acciaio inox Ø 27 mm;
- Capacità filtrante 20 l/min

#### Valvola regolatrice di pressione

- Per pompe fino a 20 l/min (tipo REMCO®, PROFLO®)
- Corpo in polipropilene caricato fibra vetro
- Attacco per manometro G 1/8 (BSP)
- Guarnizioni in EPDM
- Parti interne in DELRIN e acciaio INOX AISI 303
- Indicatore graduato di regolazione
- Manometro da ordinare separatamente

#### Mini suction filters

- PP body
- EPDM gaskets
- Stainless steel cartridge Ø 27 mm;
- Filtering capacity 20 l/min

#### Pressure regulating valve

- For pumps up to 20 l/min (type REMCO®, PROFLO®)
- Polypropylene body reinforced with fibreglass
- 1/8" (BSP) for manometer connection
- EPDM seals
- Internal parts in DELRIN and stainless steel AISI 303
- Regulating graduated indicator
- Manometer to order separately

#### Mini filtro del aspiracion

- Cuerpo de polipropileno
- Juntas en EPDM
- Malla en acero inox. Ø 27 mm;
- Capacidad filtrante 20 l/min

#### Válvula de regulación de presión

- Para bombas hasta 20 l/min (tipo REMCO®, PROFLO®)
- Cuerpo de Polipropileno reforzado con fibra de vidrio
- Acople por manómetro G 1/8 (BSP)
- Juntas de EPDM
- Piezas interiores de DELRIN y acero INOS AISI 303
- Índice graduado de regulación
- Manómetro a solicitar por separado

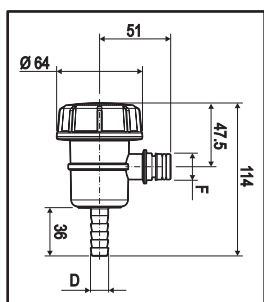

50 mesh



COD. CODE CÓD.	F	D (mm)
<b>309 TA53</b>	3D	Attacco rapido Fast coupling Acople rapido
<b>309 TB53</b>	5D	
<b>309 T953</b>	G 1/2	Filetto Thread Rosca



Ricambio  
Spare part  
Repuesto

COD. / CODE / CÓD.	tipo / type / tipo
<b>324 2003.030</b>	Inox 50 mesh

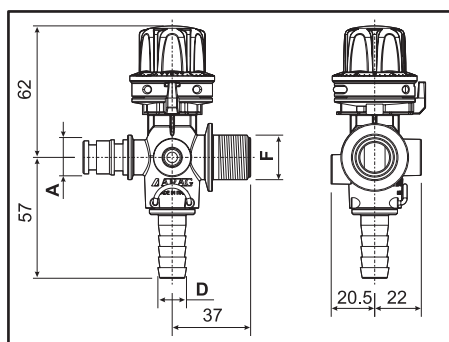

COD. CODE CÓD.	A	F (BSP)	D (mm)
<b>962 0122</b>	G 3/8M	Filetto maschio Male thread Rosca macho	13
<b>962 0222</b>	G 1/2M		
<b>962 0422</b>	3D	Attacco rapido Fast coupling Acople rapido	G 1/2M
<b>962 0522</b>	5D		
<b>962 0922</b>	G 1/2F	Girello folle femmina Loose female fly nut Tuerca libre hembra	

#### Manometro alla glicerina

#### Glycerine filled pressure gauge

#### Manómetro de glicerina



CASSA IN ABS  
ABS CASE  
CAJA EN ABS

COD. CODE CÓD.	Scala Dial Escala (Bar)	mm	BSP
<b>908 006</b>	0 ÷ 6	40	1/8"

# MANOMETRI ALLA GLICERINA GLYCERINE FILLED PRESSURE GAUGES MANÓMETROS DE GLICERINA

CASSA IN ABS  
ABS CASE  
CAJA EN ABS



Type 1

Type 2



Type 3

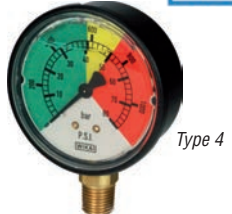

Type 4



CASSA IN INOX  
STAINLESS STEEL CASE  
CAJA DE ACERO INOXIDABLE

COMPLIANT  
EN837-1



COD. CODE CÓD.	Type	Scala Dial Escala (bar)	Class	mm		BSP	
				mm	BSP	mm	BSP
909 010	1	0 ÷ 10	2.5	63	G 1/4		
909 025	2	0 ÷ 25	2.5				
909 040	1	0 ÷ 40	2.5				
909 060	1	0 ÷ 60	2.5				
909 080	1	0 ÷ 80	2.5				
909 100	1	0 ÷ 100	2.5				

COD. CODE CÓD.	Type	Scala Dial Escala (bar)	Class	mm		BSP	
				mm	BSP	mm	BSP
910 004	3	0 ÷ 4	2.5	63	G 1/4		
910 006	3	0 ÷ 6	2.5				
910 010	3	0 ÷ 10	2.5				
910 016	3	0 ÷ 16	2.5				
910 025	4	0 ÷ 25	2.5				
910 030	3	0 ÷ 30	2.5				
910 040	3	0 ÷ 40	2.5				
910 060	3	0 ÷ 60	2.5				
910 080	4	0 ÷ 80	2.5				
910 100	3	0 ÷ 100	2.5				
910 120	3	0 ÷ 120	2.5				
910 250	3	0 ÷ 250	2.5				

COD. CODE CÓD.	Scala Dial Escala (bar)	Class	mm		BSP	
			mm	BSP	mm	BSP
911 010	0 ÷ 10	1.6	63	G 1/4		
911 016	0 ÷ 16	1.6				
911 025	0 ÷ 25	1.6				
911 040	0 ÷ 40	1.6				
911 060	0 ÷ 60	1.6				
911 100	0 ÷ 100	1.6				

COD. CODE CÓD.	Scala Dial Escala (bar)	Class	mm		BSP	
			mm	BSP	mm	BSP
913 040	0 ÷ 40	1	100	G 1/2		
913 060	0 ÷ 60	1				

CASSA IN INOX - SCALA ISOMETRICA  
STAINLESS STEEL CASE - ISOMETRIC SCALE  
CAJA DE ACERO INOXIDABLE - ESCALA ISOMÉTRICA

COMPLIANT  
EN837-1



COD. CODE CÓD.	Scala Dial Escala (bar)	Class	mm		BSP	
			mm	BSP	mm	BSP
917 0525	0 ÷ 5/25	1.6	63	G 1/4		
917 NI0525*	0 ÷ 5/25	1.6				
917 2060#	0 ÷ 20/60	1.6				
917 NI2060**	0 ÷ 20/60	1.6				

COD. CODE CÓD.	Scala Dial Escala (bar)	Class	mm		BSP	
			mm	BSP	mm	BSP
918 0525	0 ÷ 5/25	1.6	63	G 1/4		
918 2060#	0 ÷ 20/60	1.6				
918 NI2060**	0 ÷ 20/60	1.6				
919 0525	0 ÷ 5/25	1	100	G 1/2		

COD. CODE CÓD.	Scala Dial Escala (bar)	Class	mm		BSP	
			mm	BSP	mm	BSP
919 0525E	0 ÷ 5/25	1	100	G 1/4		
919 2060E	0 ÷ 20/60	1				

\* Movimento protetto con NIPLOY - NIPLOY protected movement - Movimiento protegido con NIPLOY  
#Conforme alla norma EN 12761-2/3 - EN 12761-2/3 standard compliant - Conforme a la norma EN 12761-2/3



## KIT DI PROTEZIONE PROTECTION KIT KIT DE PROTECCION

### Kit di protezione

Il kit di indumenti protettivi ARAG è stato studiato per offrire una protezione di base nella manipolazione di antiparassitari.

Il kit confezionato in una pratica sacca di PVC, è composto da:

- 1 tuta in TYVEK traspirante con cappuccio e chiusura lampo
- 1 grembiule in PVC/Poliestere pesante
- 1 paio di occhiali con lenti antiappannanti
- 2 mascherine antisolvente con intercapedine di carboni attivi
- 2 paia di guanti antisolvente in nitrile felpato internamente

### Protection kit

The ARAG protection kit has been designed to offer a basic protection for the use of crop protection chemicals.

The kit is packed in a handy PVC bag and includes:

- 1 TYVEK breathable overall with hood and zipper
- 1 heavy-duty PVC-Polyester apron
- 1 goggles with anti-fogging lenses
- 2 anti-solvent masks with activated charcoal filling
- 2 anti-solvent nitrile gloves pairs with padded interior

### Kit de protección

El kit de indumentos de protección ARAG ha sido estudiado para ofrecer una protección básica para los químicos agrícolas.

El kit, que se suministra en una práctica bolsa de PVC, está compuesto por:

- 1 Mono de TYVEK transpirable con capucha y cierre rápido con cremallera
- 1 Delantal de PVC/Poliestere muy resistente
- 1 Gafas con lentes antivaho
- 2 Mascarillas antisolventes con capa intermedia de carbón activo
- 2 PAREJAS guantes antisolvente de nitrilo, afelpados internamente





# DISPOSITIVO DI LIMITAZIONE DELLA PRESSIONE PRESSURE-RELIEF DEVICE DISPOSITIVO DE LIMITACIÓN DE LA PRESIÓN

- Il dispositivo **di limitazione** della pressione ARAG protegge i circuiti idraulici delle macchine irroratrici nel rispetto della attuale normativa UNI EN ISO 4254-6:2010 che prevede il ritorno in cisterna del liquido in scarico e il non superamento della pressione nominale dell'impianto del 20%. Il dispositivo **non sostituisce** una valvola di sicurezza.
- Non è necessario riarmare manualmente la valvola dopo una sovrappressione, ma è sufficiente interrompere momentaneamente l'erogazione di liquido
- Struttura in Nylon®-66 rinforzata con fibra di vetro
- Particolari interni in polipropilene
- Guarnizioni in Viton®
- Sigillo antimanomissione

- **Pressure relief** device ARAG protects sprayer liquid circuits according to the current European standard UNI EN ISO 4254-6:2010 which requires all overflow to be returned to the tank in discharge and a maximum overpressure up to 20% of the rated value  
This relief **does not replace** a safety valve
- No valve manual reset operation is required following an excessive increase in pressure, just momentarily interrupt the flow of liquid
- Fibreglass-reinforced Nylon-66 body
- Internal parts in polypropylene
- Gaskets made of Viton®
- Tamper-proof seal

- El dispositivo **de limitacion** de la presión ARAG protege los circuitos hidráulicos de las máquinas de pulverización, en respecto de la actual normativa UNI EN ISO 4254-6:2010 que prevé el retorno al tanque del líquido en descarga y la no superación de la presión nominal del equipo en un 20%. El dispositivo **no reemplaza** una válvula de seguridad
- No es necesario rearmar manualmente la válvula después de una sobrepresión, pues es suficiente interrumpir momentáneamente el suministro de líquido
- Estructura de Nylon-66 reforzada con fibra de vidrio
- Piezas internas de polipropileno
- Juntas de Viton®
- Sello contra manipulaciones



COD. CODE CÓD.	⚙️		🔌		∅		F	📦
	bar	PSI	lt/1'	US GPM	mm	inches		
459 110	10	145	100	26.4	13	1/2"	G 3/8	5
459 120	20	290	100	26.4	13	1/2"	G 3/8	
459 130	30	435	100	26.4	13	1/2"	G 3/8	
459 140	40	580	100	26.4	13	1/2"	G 3/8	
459 150	50	725	100	26.4	13	1/2"	G 3/8	
459 210	10	145	200	52.8	19	3/4"	G 1/2	
459 220	20	290	200	52.8	19	3/4"	G 1/2	
459 240	40	580	200	52.8	19	3/4"	G 1/2	
459 250	50	725	200	52.8	19	3/4"	G 1/2	
459 310	10	145	250	66.0	25	1"	G 3/4	
459 320	20	290	280	73.9	25	1"	G 3/4	

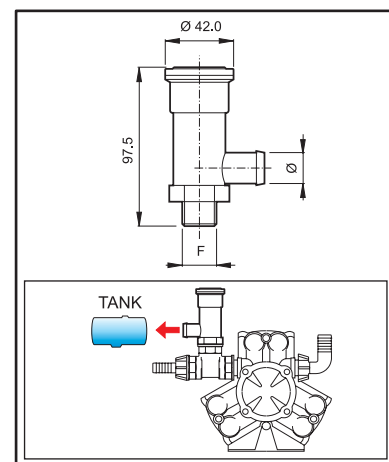

## Contenitore portadocumenti da cabina

Contenitore cilindrico da posizionare in cabina per il rimessaggio di manuali e documenti

- Staffe di fissaggio integrate nel corpo
- Corpo in Polipropilene
- Tappo a vite

## Cabin folder case

Cylindrical case to place inside the cabin for the storage of manuals and documents.

- Intergrated fixing brackets
- PP case body
- Screw cap

## Recipiente de cabina para documentos

Recipiente cilindrico de cabina para poner manuales y documentos

- Sistema de fijacion integrado en el cuerpo
- Cuerpo en Polipropileno
- Tapa roscada



COD.  
CODE  
CÓD.  
**900001**

